

# INSTRUCTION MANUAL

## RA 19-4C RACK ADAPTER

HOT SWAP RACK ADAPTER FOR  
HSF 600W, 1200W, 1500W SERIES POWER SUPPLIES

KEPCO INC.  
An ISO 9001 Company.

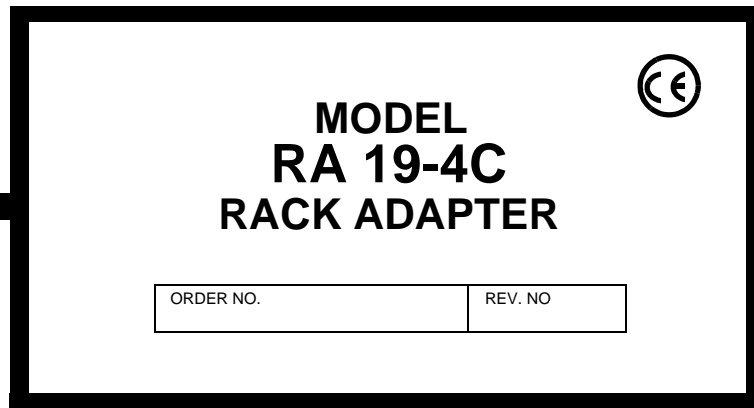

### IMPORTANT NOTES:

- 1) This manual is valid for the following Model and associated serial numbers:

| MODEL | SERIAL NO. | REV. NO. |
|-------|------------|----------|
|-------|------------|----------|
- 2) A Change Page may be included at the end of the manual. All applicable changes and revision number changes are documented with reference to the equipment serial numbers. Before using this Instruction Manual, check your equipment serial number to identify your model. If in doubt, contact your nearest Kepco Representative, or the Kepco Documentation Office in New York, (718) 461-7000, requesting the correct revision for your particular model and serial number.
- 3) The contents of this manual are protected by copyright. Reproduction of any part can be made only with the specific written permission of Kepco, Inc.

Data subject to change without notice.



# TABLE OF CONTENTS

| SECTION                         | PAGE  |
|---------------------------------|---|
| <b>SECTION 1 - INTRODUCTION</b> |   |
| 1.1                             | Scope of Manual ..... 1-1   |
| 1.2                             | General Description..... 1-1  |
| 1.3                             | Electrical..... 1-1   |
| 1.4                             | Mechanical ..... 1-3  |
| 1.5                             | Accessories ..... 1-3   |
| 1.6                             | Options ..... 1-3   |
| <b>SECTION 2 - INSTALLATION</b> |   |
| 2.1                             | Unpacking and Inspection ..... 2-1  |
| 2.2                             | Configuring the Rack Adapter ..... 2-1  |
| 2.3                             | Rack Adapter Keying Instructions ..... 2-1  |
| 2.3.1                           | Establishing Key Positions..... 2-1   |
| 2.4                             | Slot Configuration..... 2-2   |
| 2.4.1                           | Independent Operation ..... 2-3   |
| 2.4.1.1                         | Using one power supply to control Multiple Power Supplies ..... 2-3   |
| 2.4.1.2                         | Sense Connections for Independent Operation (HSF 600W Modules Only)..... 2-4                                  |
| 2.4.1.2.1                       | Independent Operation - Local Sensing Using Internal DIP switches ..... 2-5                                   |
| 2.4.1.2.2                       | Independent Operation - Local Sensing Using External Wiring ..... 2-6   |
| 2.4.1.2.3                       | Independent Operation - Remote Sensing ..... 2-7  |
| 2.4.2                           | Parallel Operation ..... 2-8  |
| 2.4.2.1                         | Voltage Control ..... 2-8   |
| 2.4.2.1.1                       | Local Control..... 2-8  |
| 2.4.2.1.2                       | Remote Control..... 2-8   |
| 2.4.2.2                         | Parallel, Master Selected by User, supplying balanced current to a single load ..... 2-9                      |
| 2.4.2.3                         | Parallel, Automatic Selection of Master, supplying balanced current to a single load ..... 2-9                |
| 2.4.2.4                         | Current Balancing ..... 2-13  |
| 2.4.2.5                         | Sense Connections for Parallel Configurations (HSF 600W Modules Only) ..... 2-13                              |
| 2.4.2.5.1                       | Parallel Configuration Using DIP Switches to Connect Sense Lines in Parallel ..... 2-14                       |
| 2.4.2.5.2                       | Parallel Configurations using External Wires to Connect Sense Lines<br>in Parallel (HSF 600W Only) ..... 2-16 |
| 2.4.3                           | Series Connection ..... 2-18  |
| 2.5                             | Alarm Configurations ..... 2-20   |
| 2.5.1                           | N.O. Alarm Line (Close on Failure)..... 2-20  |
| 2.5.1.1                         | Close on Failure Using Rear Panel Dip Switches..... 2-20  |
| 2.5.1.2                         | Close on Failure Using External Wiring at I/O Mating Connector ..... 2-23                                     |
| 2.5.1.3                         | Close on Failure Using External Wiring at Alarm I/O Terminal Block ..... 2-24                                 |
| 2.5.2                           | N.C. Alarm Line (Open on Failure) ..... 2-24  |
| 2.5.2.1                         | Open on Failure Using Rear Panel Dip Switches ..... 2-25  |
| 2.5.2.2                         | Open on Failure Using External Wiring of I/O Mating Connector ..... 2-27                                      |
| 2.5.2.3                         | Open on Failure Using External Wiring of I/O Alarm Terminal Blocks..... 2-28                                  |
| 2.6                             | Terminations..... 2-28  |
| 2.7                             | Cooling ..... 2-28  |
| 2.8                             | Installation ..... 2-29   |
| 2.8.1                           | Installing Optional Protective Cover..... 2-29  |
| 2.8.2                           | Installing Optional Bus Bar ..... 2-29  |
| 2.9                             | Installing HSF Power Supplies ..... 2-30  |
| 2.10                            | Removing HSF Power Supplies ..... 2-31  |
| 2.11                            | Wiring Instructions..... 2-31   |
| 2.11.1                          | Safety Grounding..... 2-31  |
| 2.11.2                          | Source Power Connections ..... 2-31   |
| 2.11.2.1                        | EMI Compliance..... 2-32  |
| 2.11.3                          | Control Signal Connections ..... 2-33   |
| 2.11.4                          | Output Load Connections..... 2-33   |
| 2.11.4.1                        | Reducing Ripple and Noise ..... 2-33  |

# TABLE OF CONTENTS

| SECTION  |   | PAGE |
|----------|---|------|
| 2.11.4.2 | Parallel/Redundant Operation .....          | 2-33 |
| 2.11.4.3 | Series/Independent Operation .....          | 2-33 |
| 2.11.4.4 | Mixed Operation .....                       | 2-35 |
| 2.12     | Removing/Replacing HSF Power Supplies ..... | 2-35 |
| 2.13     | Shipping.....                               | 2-35 |

# LIST OF FIGURES

| FIGURE | TITLE  | PAGE |
|--------|--|------|
| 1-1    | RA 19-4C Rack Adapter .....  | vi   |
| 1-2    | RA 19-4C Rack Adapter with 600W, 1200W or 1500W HSF Power Supplies Installed .....   | 1-1  |
| 1-3    | RA 19-4C Rear Panel Interconnections .....   | 1-2  |
| 1-4    | RA 19-4C Rack Adapter Rear Panel .....   | 1-3  |
| 1-5    | RA 19-4C Schematic Diagram .....   | 1-5  |
| 1-6    | RA 19-4C-26417 mechanical Outline Dimensions .....   | 1-7  |
| 2-1    | RA 19-4C Rack Adapter Keying .....   | 2-2  |
| 2-2    | Controlling Multiple Power Supplies, Multiple Loads .....  | 2-4  |
| 2-3    | Independent Operation, Local Sensing for PS1 and PS2 using<br>Internal DIP switches, Simplified Diagram .....  | 2-5  |
| 2-4    | Independent Operation, Local Sensing for PS1 and PS2 using<br>External Wiring, Simplified Diagram .....  | 2-6  |
| 2-5    | Independent Operation, Remote Sensing for PS1 and PS2 using<br>External Wiring at I/O Mating Connector or Euroblock, Simplified Diagram .....                  | 2-7  |
| 2-6    | Parallel, Master-Slave, Single Load, HSF DIP Switches Define Master and<br>Voltage Control, RV, COM and CB lines Paralleled by Rack Adapter DIP Switches ..... | 2-10 |
| 2-7    | Master-Slave, Single Load, HSF DIP Switches Define Master and Voltage<br>Control, RV, COM and CB lines Paralleled by External Wiring at I/O Connector .....    | 2-11 |
| 2-8    | Parallel Connection, Master-Slave, Single Load, Master Determined by Highest Output Voltage .....  | 2-12 |
| 2-9    | Typical Parallel Connections Using External Wires for Local/Remote<br>Sensing and DIP switches to parallel sense wires (HSF 600W only) .....                   | 2-15 |
| 2-10   | Typical Parallel Connections using External Wires for Local/Remote<br>Sensing and I/O Mating Connector Jumpers to Parallel sense wires (HSF 600W Only) .....   | 2-17 |
| 2-11   | Series Connection .....  | 2-19 |
| 2-12   | Typical Close on Failure Alarm Configuration Using Rear Panel Dip Switches<br>with Output from I/O Mating Connector, Simplified Diagram .....                  | 2-21 |
| 2-13   | Typical Close on Failure Alarm Configuration Using Rear Panel Dip<br>Switches, with Output from Alarm I/O Terminal Blocks, Simplified Diagram .....            | 2-22 |
| 2-14   | Close on Failure Alarm Configuration Using External Wiring at<br>I/O Mating Connector, Simplified Diagram .....  | 2-23 |
| 2-15   | Close on Failure Alarm Configuration Using External Wiring at<br>Alarm I/O Terminal Block, Simplified Diagram .....  | 2-24 |
| 2-16   | Typical Open on Failure Alarm Configuration Using Rear Panel Dip Switches<br>with Output from I/O Mating Connector, Simplified Diagram .....                   | 2-25 |
| 2-17   | Typical Open on Failure Alarm Configuration Using Rear Panel Dip Switches<br>with Output from Alarm I/O Terminal Blocks, Simplified Diagram .....              | 2-26 |
| 2-18   | Open on Failure Alarm Configuration Using External Wiring<br>at I/O Mating Connector, Simplified Diagram .....   | 2-27 |
| 2-19   | Open on Failure Alarm Configuration Using External Wiring<br>at I/O Alarm Terminal Blocks, Simplified Diagram .....  | 2-28 |
| 2-20   | Optional Protective Cover or Bus Bar Installation .....  | 2-30 |
| 2-21   | Ripple and Noise Measurement Setup Diagram .....   | 2-34 |

# LIST OF TABLES

| TABLE | TITLE  | PAGE |
|-------|--|------|
| 1-1   | Compatible HSF Power Supplies .....  | 1-4  |
| 1-2   | RA 19-4C Accessories .....   | 1-4  |
| 2-1   | Equipment Supplied .....   | 2-1  |
| 2-2   | Rear Panel DIP Switch Functions .....  | 2-2  |
| 2-3   | HSF DIP Switch Configuration for Master/slave AND Voltage Control of Parallel Multiple Units ..... | 2-9  |
| 2-4   | HSF DIP Switch Configuration for Voltage Control of Multiple Units in Series .....                 | 2-18 |



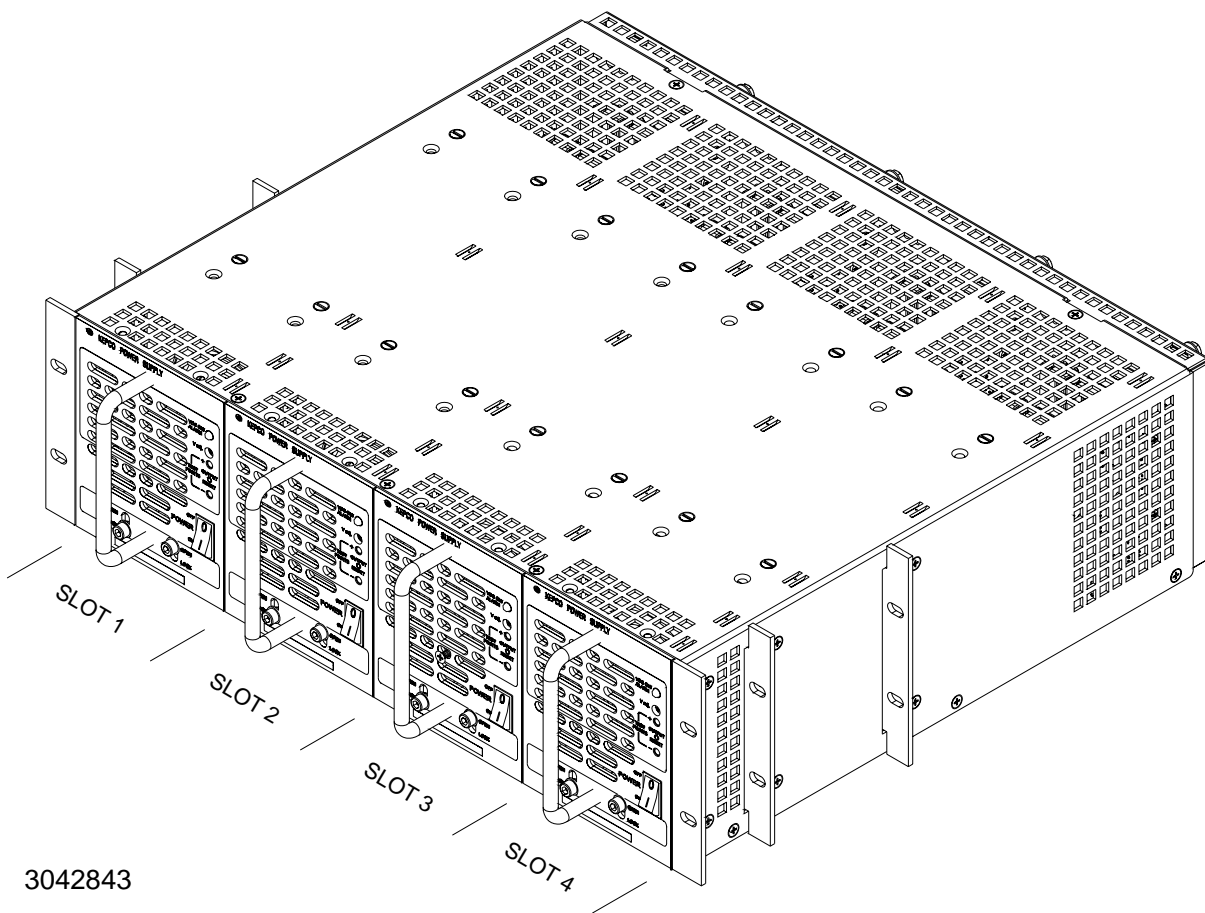

3042843

FIGURE 1-1. RA 19-4C RACK ADAPTER



## SECTION 1 - INTRODUCTION

### 1.1 SCOPE OF MANUAL

This manual contains instructions for the installation and operation of the RA 19-4C plug-in rack adapter (Figure 1-1) used with 600W, 1200W and 1500W HSF power supplies, manufactured by Kepco, Inc., Flushing, New York, U.S.A.

### 1.2 GENERAL DESCRIPTION

Kepco RA 19-4C rack adapters are specifically designed for the installation of Kepco 600W, 1200W and 1500W HSF Power Supplies into 19-inch EIA-RS-310D standard equipment racks. The RA 19-4C Model accommodates up to four 600W, 1200W or 1500W HSF power supplies (Figure 1-2).

The rack adapter is user-configurable for parallel, series, or independent power supply operation. Forced current sharing and OR'ing diodes for N+1 redundancy are built into the HSF power supplies. Redundant a-c inputs are provided to deliver independent source power to each power supply in a redundant pair. User-configurable keying ensures that only the correct power supply can be installed in a keyed slot.

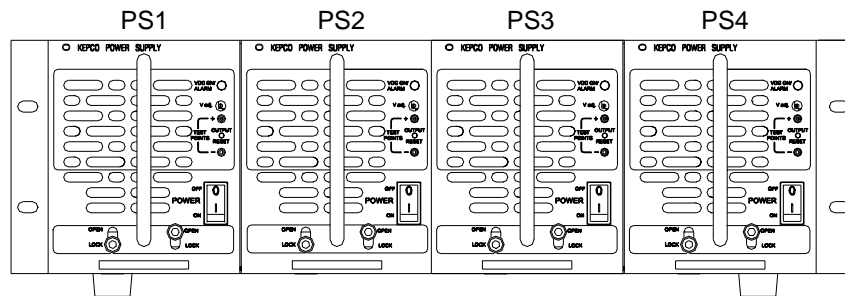

3042844

FIGURE 1-2. RA 19-4C RACK ADAPTER WITH 600W, 1200W OR 1500W HSF POWER SUPPLIES INSTALLED

### 1.3 ELECTRICAL

An internal PCB back plate mounts connectors which interface directly with the power and signal connectors of 600W, 1200W and 1500W HSF power supplies, permitting hot swappable insertion and extraction. The other side of the back plate assembly, available from the rear, contains the fixed power and signal connections. Figure 1-3 shows RA 19-4C Rack Adapter interconnections as well as details of the connectors and DIP switches located on the rear panel (see Figure 1-4). Dual input terminal blocks on the rear panel (Figure 1-4) distribute input power to each of the four power supplies. Figure 1-5 is a schematic diagram of the RA 19-4C Rack Adapter.

All mechanical specifications are contained in the mechanical outline drawing, Figure 1-6.

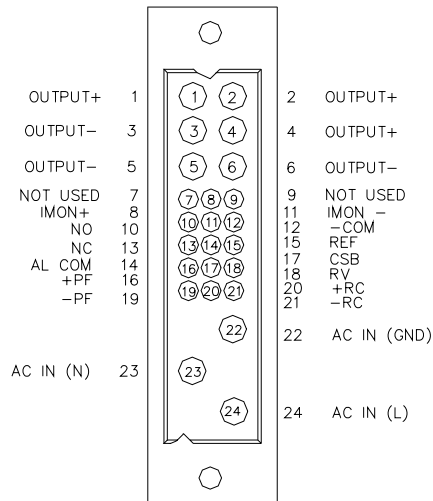
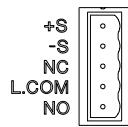
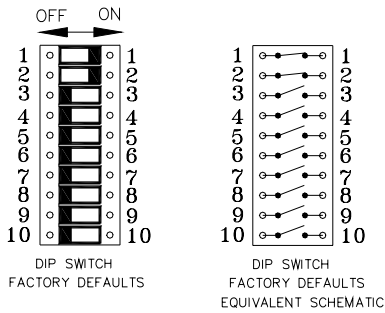
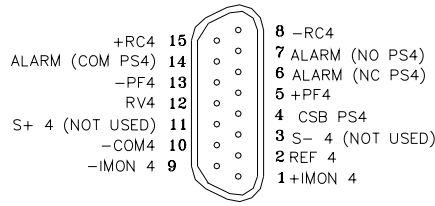
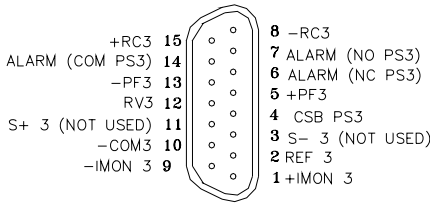
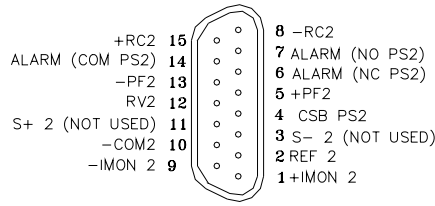
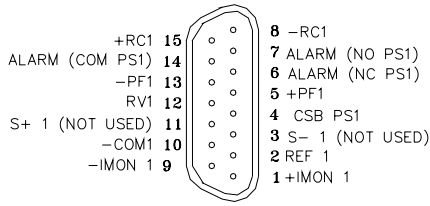
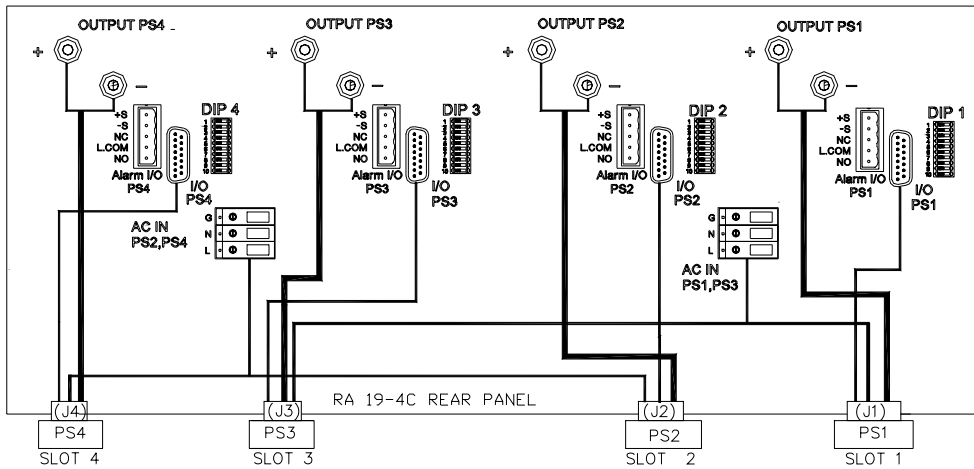

3042847

**FIGURE 1-3. RA 19-4C REAR PANEL INTERCONNECTIONS**

## 1.4 MECHANICAL

The rack adapter is equipped with mounting ears for mounting in EIA-RS-310D standard 19-inch racks. For mounting in non-standard racks, consult Kepco Applications Engineering. The rack adapter is not configured for slides. Optional blank filler panels (see Table 1-2) are available if the full complement of power supplies is not utilized.

Mechanical dimensions, material, and finish of the RA 19-4C Rack Adapter are provided in Figure 1-6.

## 1.5 ACCESSORIES

Accessories for RA 19-4C Rack Adapters are listed in Table 1-2; see also Table 2-1 for additional accessories supplied with the unit.

## 1.6 OPTIONS

Table 1-1 describes the standard model options available with the RA 19-4C rack adapter. For non-standard options, contact Kepco Applications Engineering for assistance.

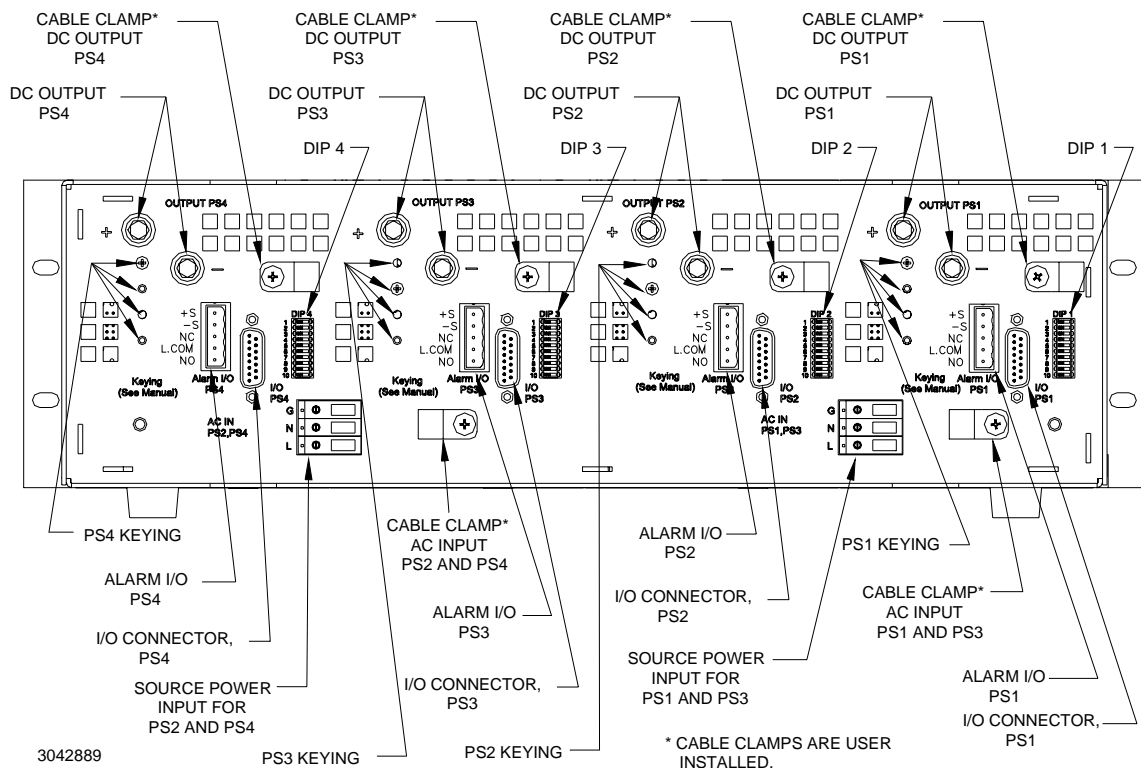

**FIGURE 1-4. RA 19-4C RACK ADAPTER REAR PANEL**

**TABLE 1-1. COMPATIBLE HSF POWER SUPPLIES**

| MODEL    | Total   | Compatible HSF Models |            |                    |
|----------|---------|-----------------------|------------|--------------------|
|          |         | 1200 Watts            | 1500 Watts | 600 Watts          |
| RA 19-4C | 4 (max) | HSF 24-50             | HSF 48-32  | HSF ???<br>HSF ??? |

\* Contact Kepco Applications Engineering for assistance with non-standard configurations.

**TABLE 1-2. RA 19-4C ACCESSORIES**

| ACCESSORY   | PART NUMBER | USE   |
|---|-------------|---|
| Screw, Thread forming (4-40, 0.75 in. long, PHPH) | 101-0480    | Module Keying. eight (8) supplied with unit. Installed by user (see PAR. 2.3).  |
| Line cord   | 118-1145    | Connect to 30A, 125-250V a-c source power via NEMA 10-30P connection.   |
| Line cord   | 118-1146    | Connect to 32A, 250V a-c source power via IEC 309 connection.   |
| Connector   | 142-0449    | Mating Connector for I/O connector. Four (4) supplied with unit.  |
| Filler Panel (1/4 Rack)                           | RFP 19-14C  | Cover one unused 1/4 rack slot.   |
| Filler Panel (1/2 Rack)                           | RFP 19-12C  | Cover two unused 1/4 rack slots.  |
| Bus bar, Series                                   | 172-0593    | Connect Output Terminals, (-) to (+) for series operation.  |
| Bus bar, Parallel, 2 Slots                        | 172-0590    | Connect slots 1 and 2, 2 and 3, or 3 and 4 in parallel; two bus bars required for each paralleled slot: one for (+), one for (-).                               |
| Bus Bar, Parallel, 3 Slots                        | 172-0591    | Connect slots 1, 2 and 3, or 2, 3 and 4 in parallel; two bus bars required for each paralleled set of slots: one for (+), one for (-).                          |
| Bus Bar, Parallel, 4 Slots                        | 172-0592    | Connect slots 1 through 4 in parallel; two bus bars required for each rack adapter: one for (+), one for (-).   |
| Hex Nut (5/16-18)                                 | 102-0105    | Attach load cables to studs of optional bus bars.   |
| Protective cover                                  | 137-0145    | Clear plastic cover, protects against accidental contact with DC output terminals. Four standoffs (not supplied), Kepco P/N 104-0385, required for installation |
| Standoff (Protective cover)                       | 104-0385    | Four (4) required to install protective cover, Kepco P/N 137-0145. Male/female, 8-32 x 1.5 in. long   |
| Setback Ear Brackets (2 required)                 | 128-2168    | Used to mount rack adapter in 19-inch rack using "set back" position for applications that require reduced depth protrusion (see Figure 1-6).                   |
| Screws ((8 required, 4 for each ear bracket)      | 101-0446    | Used to attach ear brackets to rack adapter chassis.(6-32 x 1/4, Flat Head Phillips Tri-torq, Tubular Self Forming.   |
| Connector, Euro-plug                              | 142-0544    | Mating connector for ALARM TB1-TB4 Euro-header.   |
| Slide Kit (bottom mount)                          | 219-0508    | Allows rack adapter to slide out from the front. Requires 1U (1.75 in.) minimum height)   |

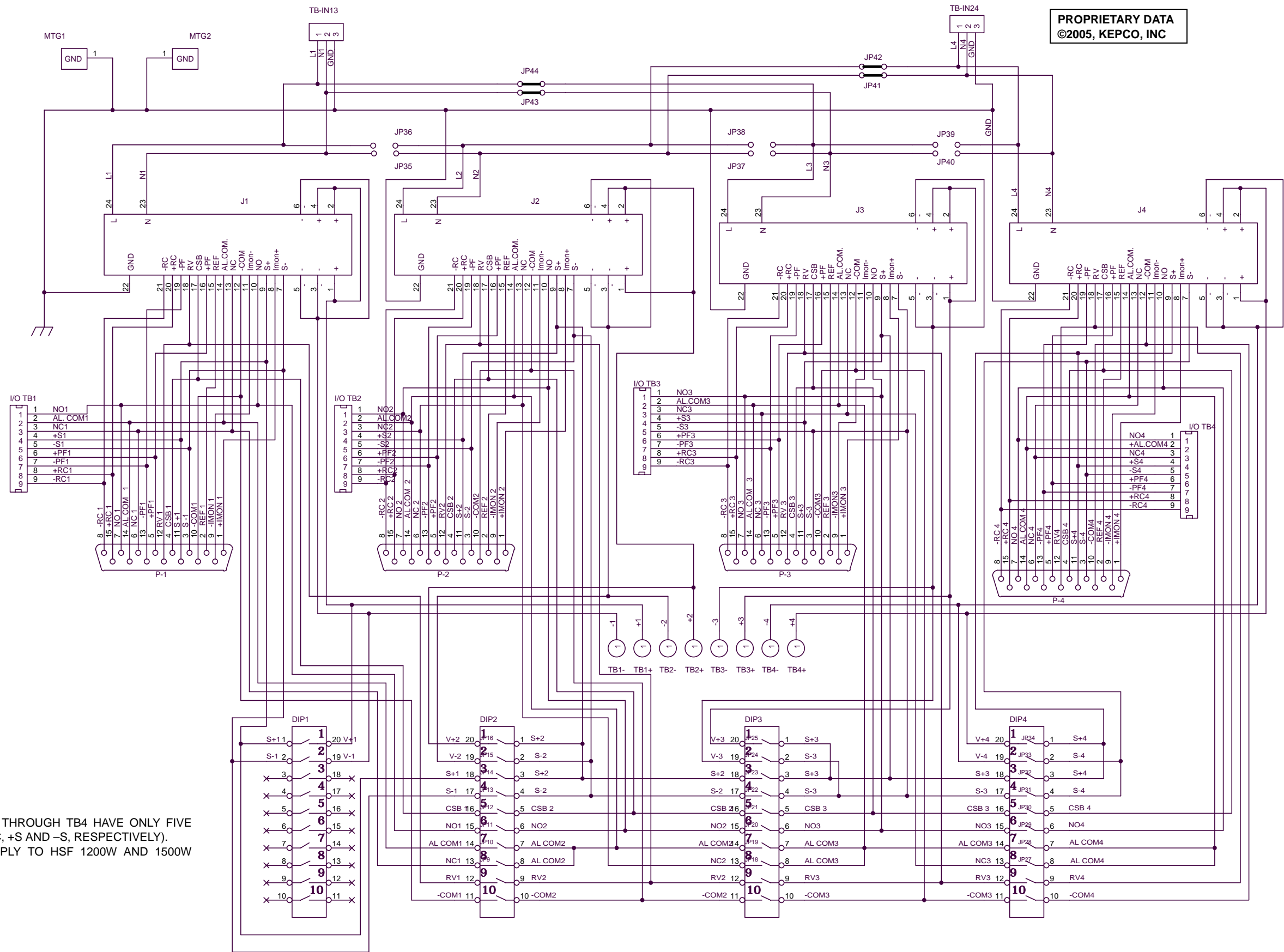

- NOTES:
1. ALARM I/O TERMINAL BLOCKS TB1 THROUGH TB4 HAVE ONLY FIVE PINS: 1 THROUGH 5 (NO, AL COM, NC, +S AND -S, RESPECTIVELY).
  2. SENSE CONNECTIONS DO NOT APPLY TO HSF 1200W AND 1500W UNITS.

3020736

FIGURE 1-5. RA 19-4C SCHEMATIC DIAGRAM



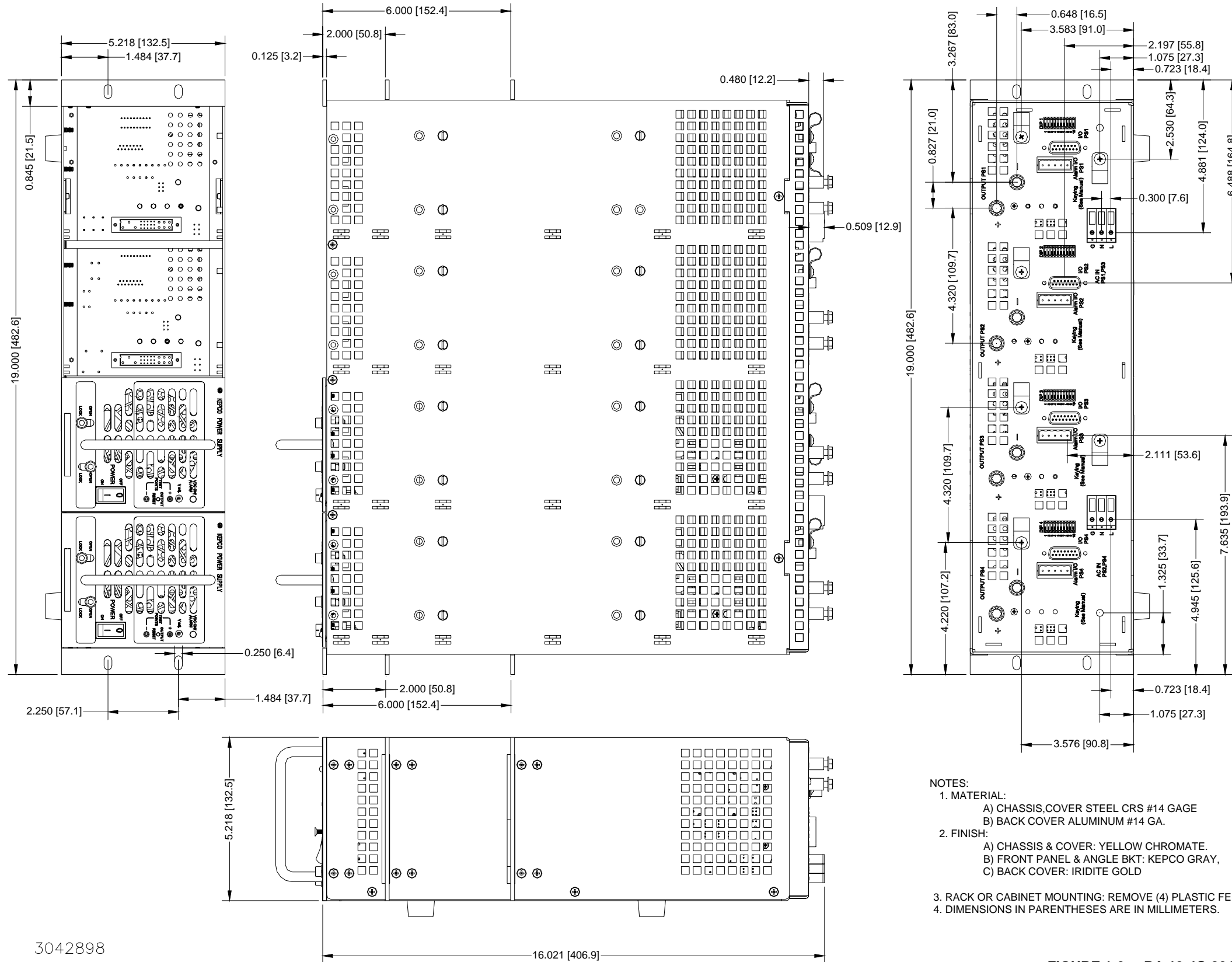

- NOTES:
- MATERIAL:
    - CHASSIS, COVER STEEL CRS #14 GAGE
    - BACK COVER ALUMINUM #14 GA.
  - FINISH:
    - CHASSIS & COVER: YELLOW CHROMATE.
    - FRONT PANEL & ANGLE BKT: KEPCO GRAY,
    - BACK COVER: IRIDITE GOLD
  - RACK OR CABINET MOUNTING: REMOVE (4) PLASTIC FEET
  - DIMENSIONS IN PARENTHESES ARE IN MILLIMETERS.

FIGURE 1-6. RA 19-4C-26417 MECHANICAL OUTLINE DIMENSIONS





## SECTION 2 - INSTALLATION

### 2.1 UNPACKING AND INSPECTION

This equipment has been thoroughly inspected and tested prior to packing and is ready for operation. After careful unpacking, inspect for shipping damage before attempting to operate. If any indication of damage is found, file an immediate claim with the responsible transport service. See Table 2-1 for a list of equipment supplied.

**TABLE 2-1. EQUIPMENT SUPPLIED**

| ITEM  | QUANTITY | PART NUMBER |
|---|----------|-------------|
| Rack Adapter  | 1        | RA 19-4C    |
| I/O Connector (Mating)  | 4        | 142-0449    |
| Instruction Manual  | 1        | 243-1130    |
| Keying screws (4-40 x 0.75 in., thread forming)                     | 8        | 101-0480    |
| Hood for I/O Connector (Mating) P/N 142-0449                        | 4        | 108-0204    |
| Cable clamp   | 6        | 138-0063    |
| Chassis Feet  | 4        | 158-0008    |
| Output connection screw (10-32 x 1/2, Hex head)                     | 8        | 101-0365    |
| Output connection washer #10 (ID: 0.210, OD: 0.433 .039 thk, steel) | 8        | 103-0136    |

### 2.2 CONFIGURING THE RACK ADAPTER

Prior to installation the rack adapter must be configured by the user. Configuration consists of the following:

- For configurations that use multiple output voltages it is possible to key the rack adapter to accept only a power supply with corresponding keying (see PAR 2.3).
- Configuring slots for independent, parallel, or series operation. This can be done by means of DIP switches mounted on the rear panel, or externally by wiring the associated I/O mating connector or mating Euro plug and (+) and (-) OUTPUT terminals (see PAR. 2.4).

### 2.3 RACK ADAPTER KEYING INSTRUCTIONS

RA 19-4C rack adapters incorporate a keying mechanism to prevent accidental insertion of the incorrect model HSF power supply into any position. The HSF power supplies are keyed by voltage at the factory. The keying mechanism will prevent engagement of any of the HSF power supply's connectors with those on the rack adapter's back plate unless the key and keyway align. The key pins are on the HSF power supply and are set at the factory. **DO NOT ALTER THE KEYING AT THE POWER SUPPLY.** The keyway is established by installing screws (provided) so that the only open holes match the power supply pins; maximum torque is 5 in.-lbs. The user can configure each power supply slot for the desired voltage in the desired position. Figure 1-4 shows the location of key positions for each slot and Figure 2-1 shows the configuration required for voltage selection.

#### 2.3.1 ESTABLISHING KEY POSITIONS

To establish the keying of any position, simply install the 4-40 x 0.75 in. thread-forming screws (Keeco P/N 101-0480) into the corresponding holes as indicated in Figure 2-1. **DO NOT OVER-**

TIGHTEN these screws (max torque 5 in.-lbs. (0.6 N x m). DO NOT ALTER THE KEYING AT THE POWER SUPPLY.

| DESIRED VOLTAGE →                       | 12V | 15V | 24V | 28V | 48V |
|---|-----|-----|-----|-----|-----|
| ⊕ = SCREW TO BE INSTALLED AT REAR PANEL | ⊕   | ○   | ⊕   | ○   | ○   |
| ○ = NO SCREW INSTALLED.                 | ○   | ○   | ○   | ⊕   | ⊕   |
|   | ○   | ⊕   | ⊕   | ○   | ⊕   |
|   | ⊕   | ⊕   | ○   | ⊕   | ○   |

3042848

FIGURE 2-1. RA 19-4C RACK ADAPTER KEYING

## 2.4 SLOT CONFIGURATION

Configuring slots of the rack adapter for independent, parallel or series operation is accomplished either by means of DIP switches mounted on the rear panel associated with each slot (see Figure 1-3), or externally by connecting the appropriate pins of the associated I/O mating connector. DIP switch functions are explained in Table 2-2. The schematic diagram (Figure 1-5), which shows all internal connections, is provided as a reference.

Slot configuration requires the following selection:

1. Select independent (PAR. 2.4.1), parallel (PAR. 2.4.2), or series (PAR. 2.4.3) operation.
2. Optional: Select close-on-failure or open-on-failure alarm (PAR. 2.5).

TABLE 2-2. REAR PANEL DIP SWITCH FUNCTIONS

| DIP SWITCH POSITION   | FUNCTION                          | DIP SWITCH SET TO ON (CLOSED)   | DIP SWITCH SET TO OFF (OPEN)  |
|---|-----------------------------------|---|---|
| NOTE: <b>BOLD TYPE</b> INDICATES FACTORY SETTINGS.  |                                   |   |   |
| 1, 2<br>(SEE NOTE)  | Local / Remote Sensing Selection  | <b>Required ON (factory default) for independent operation with Local Sensing. Position 1 connects V+ to S+, Position 2 connects V- to S- (see PAR. 2.4.1.2).</b>   | Position 1 and 2 required OFF for:<br>a) Independent configurations using Remote Sensing (see PAR. 2.4.1.2).<br>b) Independent configurations using Local Sensing with user supplied connections from V+ to S+ and V- to S- (see PAR. 2.4.1.2).<br>c) All parallel configurations (sensing must be established using external wires) (see PAR. 2.4.2.5).<br>d) All series connections (see PAR. 2.4.3). |
| 3, 4<br>(SEE NOTE)  | Connect Sense + and - in parallel | Required ON for parallel configurations using DIP switch settings to connect the sense leads in parallel. Position 3 connects +S to adjacent slot +S, Position 4 connects -S to adjacent slot -S (see PAR.2.4.2.5.1 (DIP switches) and 2.4.2.5.2 (external wiring). | <b>Position 3 and 4 required OFF (factory default) for all configurations except parallel configurations using DIP switch settings to connect the sense leads in parallel.</b>  |
| NOTE: Positions 1, 2, 3, 4 not used for HSF 1200W and 1500W modules; leave in default position. |                                   |   |   |

**TABLE 2-2. REAR PANEL DIP SWITCH FUNCTIONS (CONTINUED)**

| DIP SWITCH POSITION | FUNCTION               | DIP SWITCH SET TO ON (CLOSED)   | DIP SWITCH SET TO OFF (OPEN)   |
|---------------------|------------------------|---|--|
| 5                   | Current Balance        | Required ON for parallel operation (connects current share lines in parallel) unless connections are made via external wires (see PAR. 2.4.2.3 and 2.4.2.4).  | <b>Required OFF (factory default) for</b><br><b>a) independent and series configurations.</b><br><b>b) Parallel configurations using external wires at I/O connector to connect CSB (current share bus) lines in parallel.</b> |
| 6, 7                | Close on Failure Alarm | When set to ON, individual power supplies produce closure between I/O connector N.O. and COM pins upon failure (see PAR. 2.5.1).                              | <b>When set to OFF (factory default), allows a single alarm to provide failure indication (contact closure between N.O. pin and COM pin) if any one of many power supplies fails (see PAR. 2.5.1).</b>                         |
| 8                   | Open on Failure Alarm  | When set to ON, individual power supplies produce open between I/O connector N.C. and COM pins upon failure (see PAR. 2.5.2).                                 | <b>When set to OFF (factory default), allows a single alarm to provide failure indication (contact open between N.C. pin and COM pin) if any one of many power supplies fails (see PAR. 2.5.2).</b>                            |
| 9                   | Remote Voltage         | When set to ON, enables control of multiple supplies from power supply designated as the Master. Used only for power supplies with Current Share capability.) | <b>When set to OFF allows independent voltage control of each power supply</b>   |
| 10                  | -Common                | When set to ON, enables control of multiple supplies from power supply designated as the Master. Used only for power supplies with Current Share capability.) | <b>When set to OFF allows independent voltage control of each power supply</b>   |

NOTE: Positions 1, 2, 3, 4 not used for HSF 1200W and 1500W modules; leave in default position.

## 2.4.1 INDEPENDENT OPERATION

The rack adapter is preconfigured at the factory for independent operation of all slots. DIP switch positions 3 through 5 associated with each slot must be set to OFF (open) for each power supply to be operated independently. *HSF 600W modules must have sense connections configured to work properly (see PAR. 2.4.1.2).*

### 2.4.1.1 USING ONE POWER SUPPLY TO CONTROL MULTIPLE POWER SUPPLIES

Figure 2-2 shows the connection of three power supplies each having an independent load. In this configuration the output voltage of all three power supplies is controlled by one power supply (master) and the current drawn by each power supply is determined by the respective load. Refer to PAR. 2.4.2.1 to select local or remote voltage control.

The connections between RV and -COM may be made using the rack adapter DIP switches or by wiring the I/O mating connector as shown in Figure 2-2. Using external wiring at the I/O mating connector allows configuration of non-adjacent slots. Use shielded wire for connections to RV pins. *HSF 600W modules MUST have sense connections configured to work properly (see PAR. 2.4.1.2)*

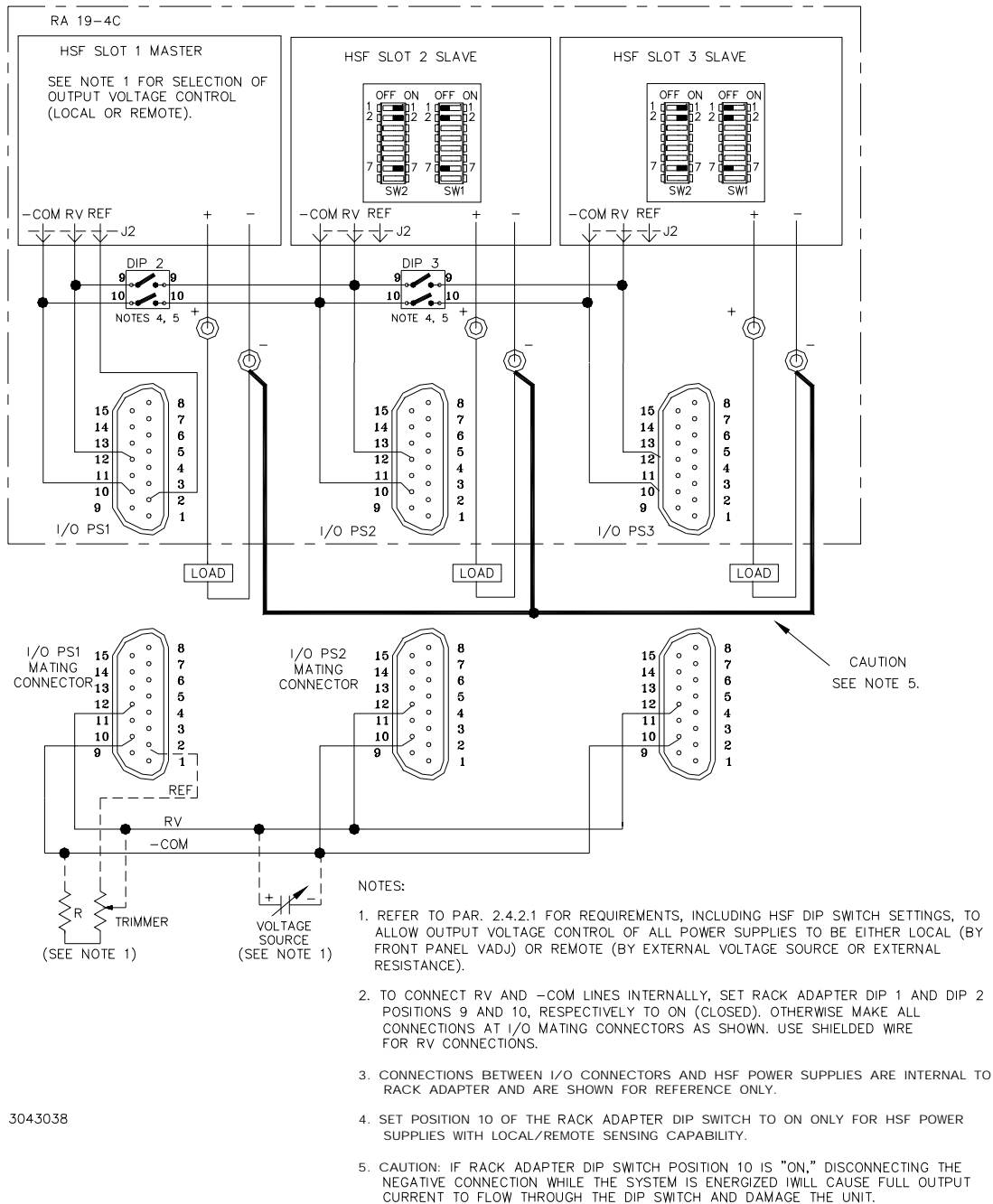

3043038

**FIGURE 2-2. CONTROLLING MULTIPLE POWER SUPPLIES, MULTIPLE LOADS**

### 2.4.1.2 SENSE CONNECTIONS FOR INDEPENDENT OPERATION (HSF 600W MODULES ONLY)

The rack adapter is shipped from the factory with each power supply position configured for local sensing (see Figure 2-3). Sensing for each slot can be configured independently:

- Local sensing using internal DIP switches
- Local sensing using external jumpers connected to the I/O mating connector or the DC OUTPUT terminal block.
- Remote sensing

### 2.4.1.2.1 INDEPENDENT OPERATION - LOCAL SENSING USING INTERNAL DIP SWITCHES

The rack adapter slots are preconfigured at the factory for local sensing using internal DIP switches. If a slot has been configured for other than local sensing using DIP switches and it is necessary to reconfigure it for local sensing, simply set positions 1 and 2 of the DIP switch associated with that slot to ON (closed). External sensing connections must be removed. When set to ON (closed) DIP switch position 1 connects (V+) to (S+) and position 2 connects (V-) to (S-). See Figure 1-3 for DIP switch locations. Figure 2-3 illustrates local sensing of PS1 and PS2 by setting positions 1 and 2 of internal DIP switches B3 and C4 to ON (closed); positions 3 and 4 must be set to OFF (open). Position 5 (current share) must be set to OFF and positions 6, 7, and 8 (alarms) can be configured per PAR. 2.5.

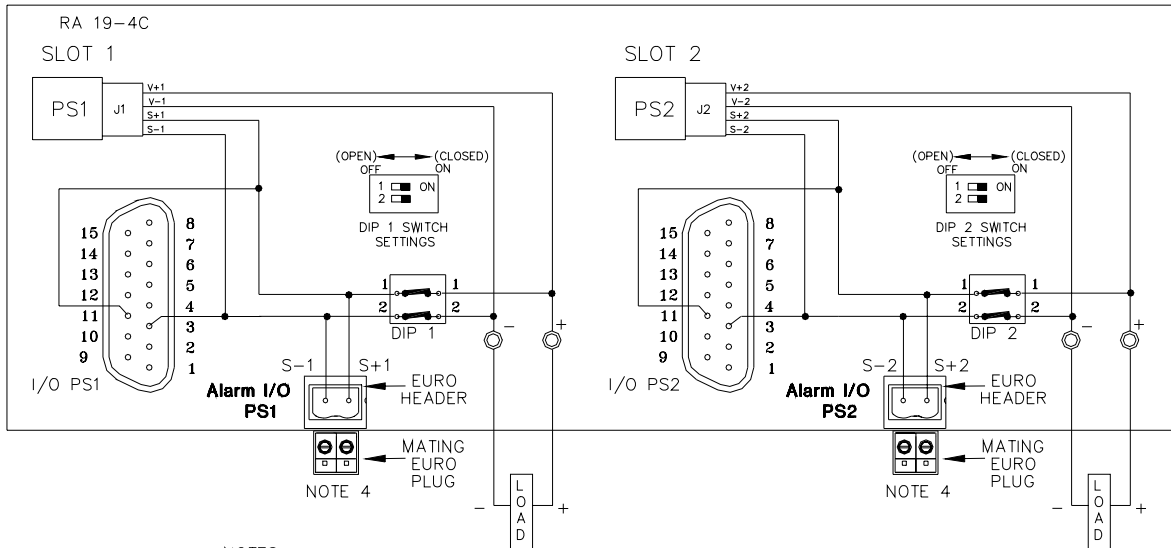

NOTES:

1. SET DIP SWITCH POSITIONS 1 AND 2 TO ON (CLOSED) FOR LOCAL SENSING. NO OTHER SENSE CONNECTIONS ARE REQUIRED.
2. CONNECTIONS TO I/O CONNECTORS, EURO HEADERS AND DIP SWITCHES ARE INTERNAL AND SHOWN FOR REFERENCE ONLY.
3. I/O MATING CONNECTOR VIEWED FROM FRONT (MATING FACE) FOR EASE OF LOCATING CORRESPONDING I/O CONNECTOR PINS.
4. ONLY TWO POSITIONS SHOWN.

3042908

**FIGURE 2-3. INDEPENDENT OPERATION, LOCAL SENSING FOR PS1 AND PS2 USING INTERNAL DIP SWITCHES, SIMPLIFIED DIAGRAM**

### 2.4.1.2.2 INDEPENDENT OPERATION - LOCAL SENSING USING EXTERNAL WIRING

To configure a slot for local sensing using external wiring, first set internal DIP switch positions 1 and 2 of the DIP switches associated with that slot to OFF (open).

External local sensing is accomplished by connecting (V+) to (S+) and (V-) to (S-). This can be done at either the mating I/O connector supplied (see Table 2-1) or the DC OUTPUT terminal block. See Figure 1-3 for DIP socket locations. Figure 1-3 illustrates I/O connector pin assignments. Figure 2-4 illustrates local sensing of PS1 and PS2 using external jumpers connected to the I/O mating connector.

**NOTE:** The internal DIP switch settings established at the factory for positions 1 and 2 of the associated DIP switch **MUST** be changed to OFF (open) if this option is chosen.

Positions 3 and 4 (connecting sense lines in parallel) and Position 5 (current share) must be set to OFF. Configure Positions 6, 7, and 8 (alarms) per PAR. 2.5.

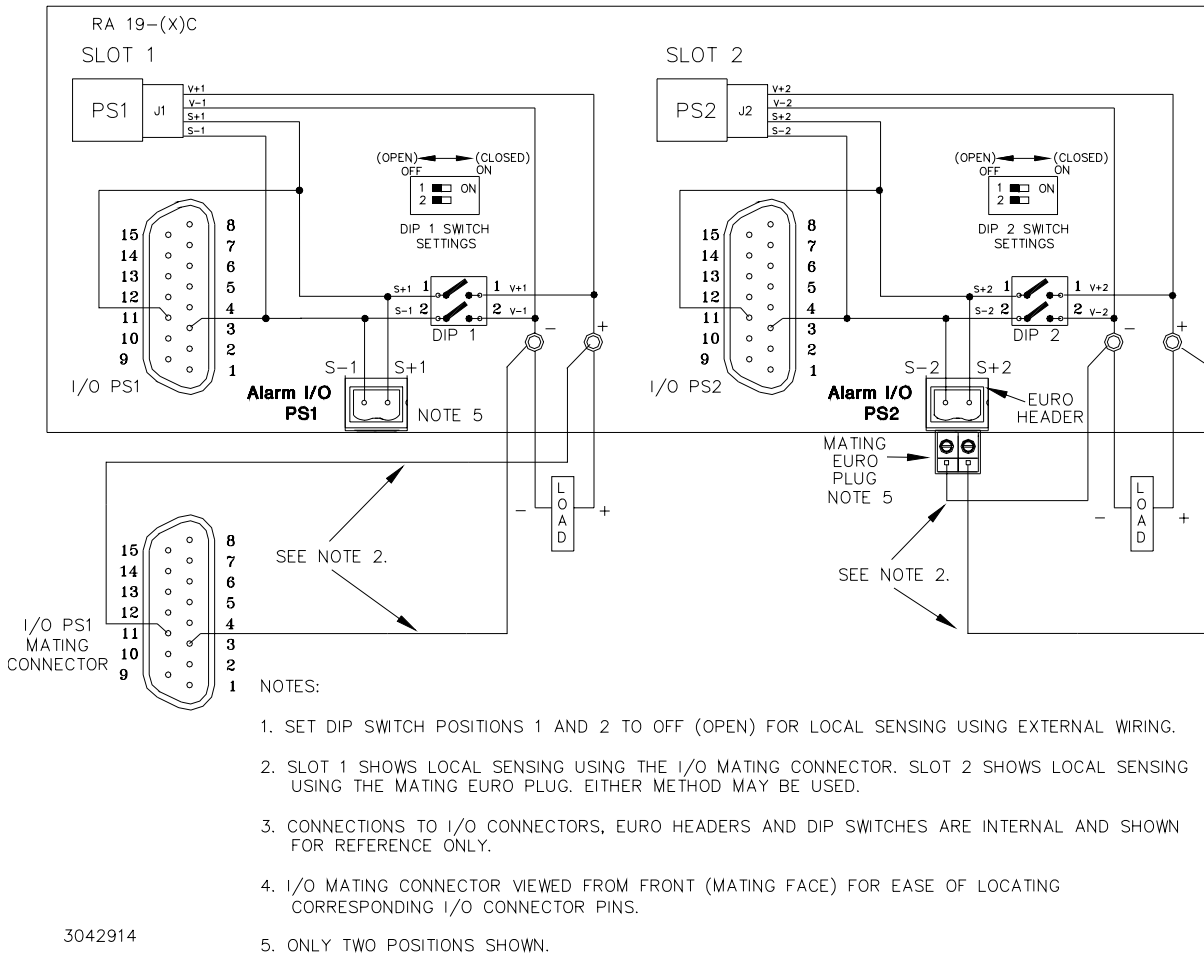

**FIGURE 2-4. INDEPENDENT OPERATION, LOCAL SENSING FOR PS1 AND PS2 USING EXTERNAL WIRING, SIMPLIFIED DIAGRAM**

### 2.4.1.2.3 INDEPENDENT OPERATION - REMOTE SENSING

Remote sensing is accomplished by connecting +Load to (S+) and -Load to (S-). Figure 2-5 illustrates remote sensing for PS1 and PS2 using wires connected to the I/O mating connector for PS1 and wires connected to the mating Euro plug for PS2.

NOTE: The internal DIP switch settings established at the factory for positions 1 and 2 of the associated DIP switch MUST be changed to OFF (open) if this option is chosen.

Positions 3 and 4 (connecting sense lines in parallel) and Position 5 (current share) must be set to OFF. Configure Positions 6, 7, and 8 (alarms) per PAR. 2.5.

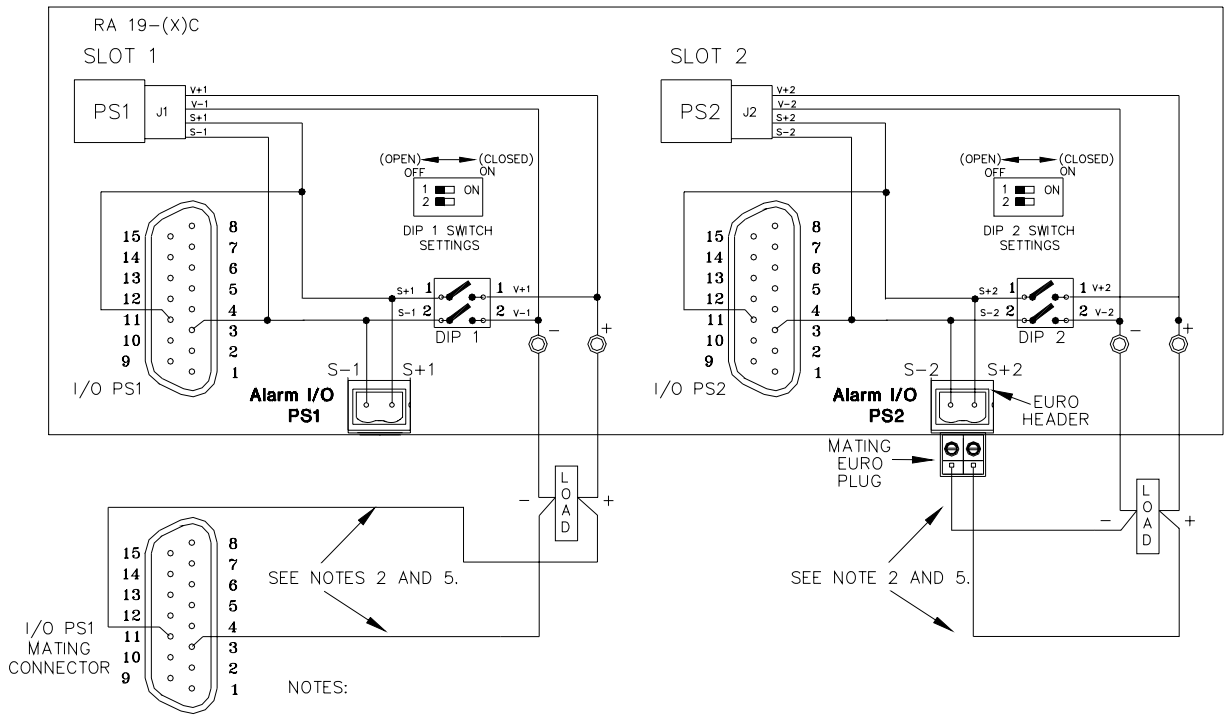

NOTES:

1. SET DIP SWITCH POSITIONS 1 AND 2 TO OFF (OPEN) FOR REMOTE SENSING USING EXTERNAL WIRING.
2. SLOT 1 SHOWS REMOTE SENSING USING THE I/O MATING CONNECTOR. SLOT 2 SHOWS REMOTE SENSING USING THE MATING EURO PLUG. EITHER METHOD MAY BE USED.
3. CONNECTIONS TO I/O CONNECTORS, EURO HEADERS AND DIP SWITCHES ARE INTERNAL AND SHOWN FOR REFERENCE ONLY.
4. I/O MATING CONNECTOR VIEWED FROM FRONT (MATING FACE) FOR EASE OF LOCATING CORRESPONDING I/O CONNECTOR PINS.
5. ONLY TWO POSITIONS SHOWN.

3042915

**FIGURE 2-5. INDEPENDENT OPERATION, REMOTE SENSING FOR PS1 AND PS2 USING EXTERNAL WIRING AT I/O MATING CONNECTOR OR EUROBLOCK, SIMPLIFIED DIAGRAM**

## 2.4.2 PARALLEL OPERATION

Compatible HSF Power Supplies (see Table 1-1) can be connected in parallel (with or without N+1 redundancy). *Connecting both 600W and 1500W models in a parallel configuration is not recommended because differently rated models will not current share.* The impedance of the load wires between each power supply and load should be the same. In addition, multiple RA 19-4C rack adapters that are fully populated with identical HSF power supplies may be paralleled using external wiring at the I/O connectors. *When using HSF 600W models, the sense lines MUST also be configured (see PAR. 2.4.2.5).*

For a single remote ON-OFF signal to turn off all parallel-connected units, at the I/O mating connectors connect together all +RC pins (pin 15) and connect together all –RC pins (pin 8).

Four things must be considered when configuring the rack adapter for parallel operation:

- VOLTAGE CONTROL
- DC OUTPUT
- CURRENT BALANCING
- SENSE CONNECTIONS (600W ONLY)

The power leads must be connected in parallel externally by connecting each power supply directly to the load; DAISY CHAIN WIRING IS **NOT PERMITTED**, however bus bars are available as accessories to make these connections when paralleling adjacent slots (refer to Table 1-2).

Control of parallel-connected modules is by configuring one unit (the master) to control all the others (slaves). The master and slaves may be either preselected by the user (PAR. 2.4.1.1), or if the output voltage of all modules is set within 2% of each other, the master will be determined automatically (PAR. 2.4.1.1). In both cases control may be from either the HSF front panel or by remote means. Current balancing is implemented to equalize the load current (see PAR. 2.4.2.4).

### 2.4.2.1 VOLTAGE CONTROL

Voltage control of the master must be configured by the two HSF DIP switches at the rear of the HSF module, **NOT** the DIP switches on the rear panel of the rack adapter.

#### 2.4.2.1.1 LOCAL CONTROL

See Table 2-3 (Vadj control) for HSF DIP switch settings. If output voltage is to be adjusted with the Vadj control, first place the configuration under an operating load. Then monitor the (+) and (.) test points on the front panel with a precision voltmeter and turn the voltage control to the desired operating value. Refer to applicable HSF manual for the recommended Adjustment Range of all the HSF Models.

#### 2.4.2.1.2 REMOTE CONTROL

See Table 2-3 (External R or V) for HSF DIP switch settings to allow the output voltage to be adjusted by either an external trimmer pot (resistance) or by an external variable voltage source. If remote control is not used, the HSF DIP switches must be set as specified in Table 2-3 (Vadj control). Refer to appropriate HSF Operator manual external resistance and external voltage requirements and operating specifications.



At the rack adapter I/O connector use a shielded wire 6.6 feet (2M) maximum in length, for connection of REF (pin 15), RV (pin 18), and –COM (pin 12) to the trimmer control or external voltage source (see Figure 2-6 or 2-8).

**TABLE 2-3. HSF DIP SWITCH CONFIGURATION FOR MASTER/SLAVE AND VOLTAGE CONTROL OF PARALLEL MULTIPLE UNITS**

| MASTER OR SLAVE | HSF DIP SWITCH POSITION (See Note) | HSF 600W     |     |                 |     | HSF 1200W, 1500W |     |                 |     |
|-----------------|------------------------------------|--------------|-----|-----------------|-----|------------------|-----|-----------------|-----|
|                 |                                    | Vadj Control |     | External R or V |     | Vadj Control     |     | External R or V |     |
|                 |                                    | SW2          | SW1 | SW2             | SW1 | SW2              | SW1 | SW2             | SW1 |
| MASTER          | Position 1 (REF)                   | OFF          | ON  | ON              | OFF | OFF              | ON  | ON              | OFF |
|                 | Position 2 (RV)                    | ON           | ON  | ON              | OFF | ON               | ON  | ON              | OFF |
|                 | Position 7 (COM)                   | OFF          | OFF | OFF             | OFF | ON               | ON  | ON              | OFF |
| SLAVE           | Position 1 (REF)                   | ON           | OFF | ON              | OFF | ON               | OFF | ON              | OFF |
|                 | Position 2 (RV)                    | ON           | OFF | ON              | OFF | ON               | OFF | ON              | OFF |
|                 | Position 7 (COM)                   | OFF          | OFF | OFF             | OFF | ON               | OFF | ON              | OFF |

NOTE: HSF DIP Switches are located at the rear of each HSF module; refer to appropriate HSF manual for location.

#### 2.4.2.2 PARALLEL, MASTER SELECTED BY USER, SUPPLYING BALANCED CURRENT TO A SINGLE LOAD

Figure 2-6 shows the connection of three power supplies in parallel to a single load. The output voltage of all slave power supplies tracks the master. The master and slaves are determined by the internal DIP switches, SW1 and SW2, of the HSF modules as defined in Table 2-3.

This configuration requires that CB (Current Balance) and RV (Remote Voltage) of all modules be tied together, using either the DIP switches at the rear of the rack adapter, as shown in Figure 2-6, or by wiring the I/O mating connector as shown in Figure 2-7. Wiring of the I/O mating connector allows non-adjacent slots to be connected in parallel.

#### 2.4.2.3 PARALLEL, AUTOMATIC SELECTION OF MASTER, SUPPLYING BALANCED CURRENT TO A SINGLE LOAD

Figure 2-8 shows a configuration in which the master is determined by whichever power supply has the highest voltage. In this configuration the output voltage of all power supplies must be set within 2% for current balancing to be in effect. The internal DIP switches, SW1 and SW2, of each HSF module must be configured to allow either the HSF front panel Vadj control or remote control of the output, either by an external voltage or an external resistance connected as shown in Figure 2-8.

This configuration requires that CB (Current Balance) and -COM (negative Common) of all modules be tied together, using either the DIP switches at the rear of the rack adapter, or by wiring the I/O mating connector as shown in Figure 2-8. Wiring of the I/O mating connector allows non-adjacent slots to be connected in parallel. If rack adapter DIP switches are used to connect the RV and –COM lines, positions 9 and 10 of adjacent modules (DIP 2 and DIP 3 in Figure 2-8) must be ON (closed). If external wiring of the I/O connector is used, positions 9 and 10 of DIP switches for adjacent modules (DIP 2 and DIP 3 in Figure 2-8) must be set to OFF (open) and the RV and –COM connections must be wired at the I/O mating connector as shown in Figure 2-8. NOTE: When connections are made at the I/O mating connector, use shielded wire for connections to RV pins. Match impedance of load wires between each power supply and load by using the same wire lengths and wire sizes.

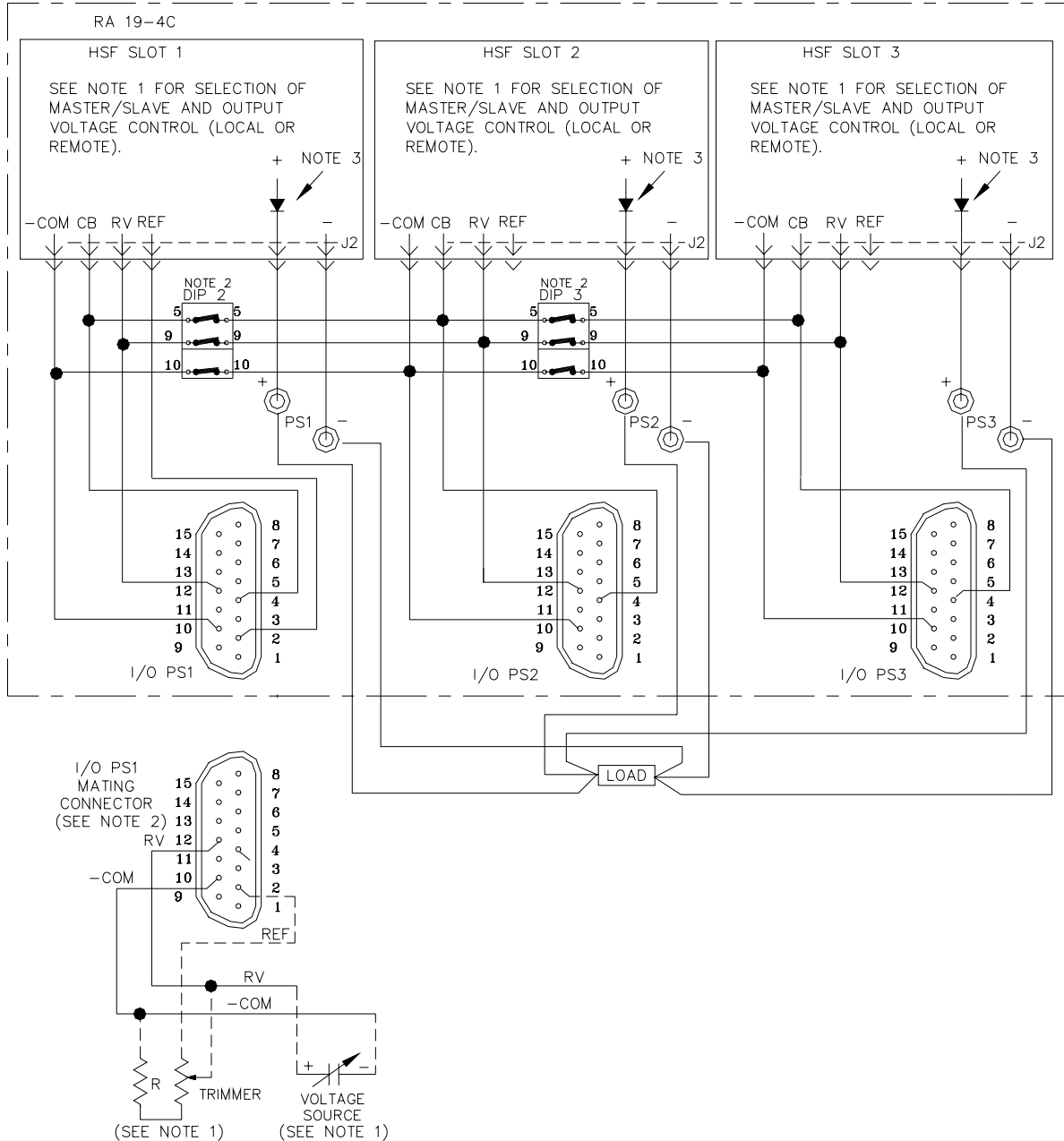

NOTES:

1. REFER TO PAR. 2.4.2.1 AND TABLE 2-3 FOR REQUIREMENTS, INCLUDING HSF DIP SWITCH, SETTINGS REQUIRED TO SELECT MASTER OR SLAVE AND TO ALLOW OUTPUT VOLTAGE CONTROL OF ALL POWER SUPPLIES TO BE EITHER LOCAL (BY FRONT PANEL VADJ) OR REMOTE (BY EXTERNAL VOLTAGE SOURCE OR EXTERNAL RESISTANCE).
2. PARALLEL CONNECTIONS FOR COM, RV AND CB ARE THROUGH DIP SWITCHES; USE I/O MATING CONNECTOR ONLY FOR REMOTE VOLTAGE CONTROL CONNECTIONS. FOR REMOTE VOLTAGE CONTROL, CONNECT REMOTE RESISTANCE OR VOLTAGE SOURCE ONLY TO MASTER.
3. ISOLATION DIODES ARE PART OF HSF POWER SUPPLY.
4. CONNECTIONS BETWEEN I/O CONNECTORS AND HSF POWER SUPPLIES ARE INTERNAL TO RACK ADAPTER AND ARE SHOWN FOR REFERENCE ONLY.

3043039

**FIGURE 2-6. PARALLEL, MASTER-SLAVE, SINGLE LOAD, HSF DIP SWITCHES DEFINE MASTER AND VOLTAGE CONTROL, RV, COM AND CB LINES PARALLELED BY RACK ADAPTER DIP SWITCHES**

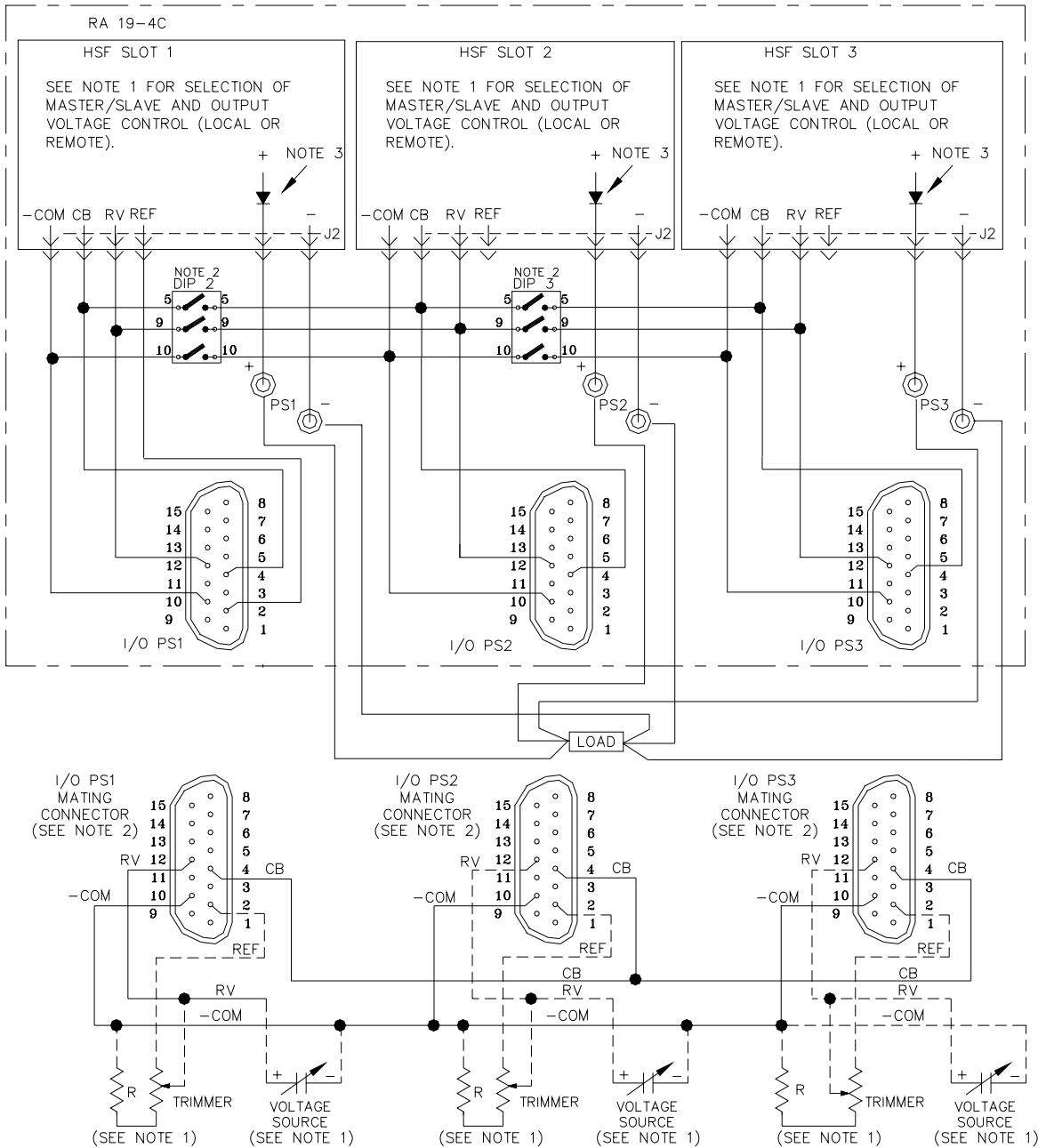

NOTES:

1. REFER TO PAR. 2.4.2.1 AND TABLE 2-3 FOR REQUIREMENTS, INCLUDING HSF DIP SWITCH, SETTINGS REQUIRED TO SELECT MASTER OR SLAVE AND TO ALLOW OUTPUT VOLTAGE CONTROL OF ALL POWER SUPPLIES TO BE EITHER LOCAL (BY FRONT PANEL VADJ) OR REMOTE (BY EXTERNAL VOLTAGE SOURCE OR EXTERNAL RESISTANCE).
2. PARALLEL CONNECTIONS FOR COM, RV AND CB ARE THROUGH I/O MATING CONNECTOR. FOR REMOTE VOLTAGE CONTROL, CONNECT REMOTE RESISTANCE OR VOLTAGE SOURCE ONLY TO MASTER.
3. ISOLATION DIODES ARE PART OF HSF POWER SUPPLY.
4. CONNECTIONS BETWEEN I/O CONNECTORS AND HSF POWER SUPPLIES ARE INTERNAL TO RACK ADAPTER AND ARE SHOWN FOR REFERENCE ONLY.

3043040

**FIGURE 2-7. MASTER-SLAVE, SINGLE LOAD, HSF DIP SWITCHES DEFINE MASTER AND VOLTAGE CONTROL, RV, COM AND CB LINES PARALLELED BY EXTERNAL WIRING AT I/O CONNECTOR**

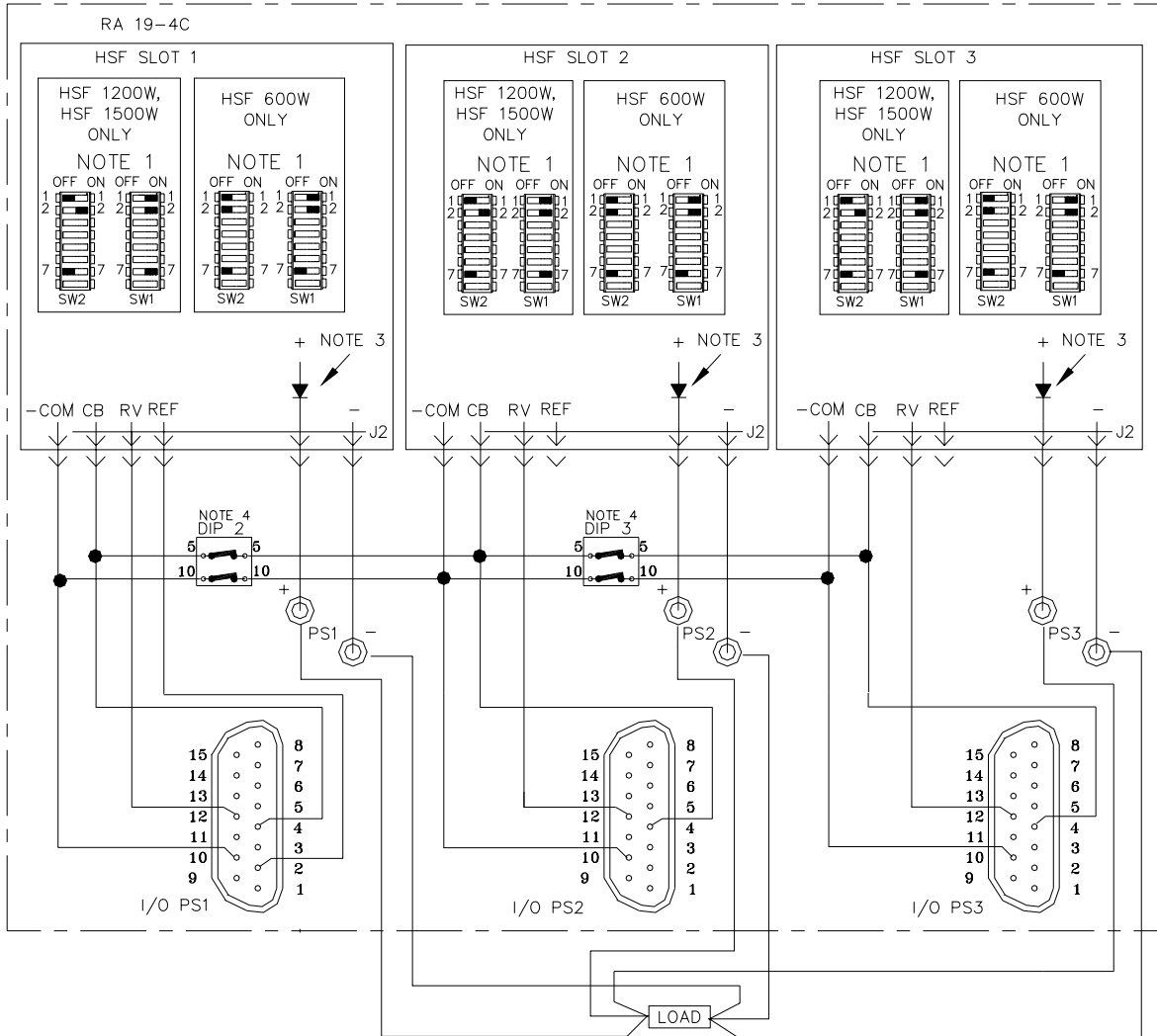

NOTES:

1. USE THESE HSF DIP SWITCH SETTINGS TO SELECT MASTER AND ALLOW FRONT PANEL VADJ TO CONTROL OUTPUT VOLTAGE OF ALL POWER SUPPLIES.
2. CB AND -COM LINES ARE PARALLELED INTERNALLY VIA RACK ADAPTER DIP 2 AND DIP 3, POSITIONS 5 AND 10, RESPECTIVELY.
3. ISOLATION DIODES ARE PART OF HSF POWER SUPPLY.
4. CONNECTIONS BETWEEN I/O CONNECTORS AND HSF POWER SUPPLIES ARE INTERNAL TO RACK ADAPTER AND ARE SHOWN FOR REFERENCE ONLY.

3043041

**FIGURE 2-8. PARALLEL CONNECTION, MASTER-SLAVE, SINGLE LOAD, MASTER DETERMINED BY HIGHEST OUTPUT VOLTAGE**

#### 2.4.2.4 CURRENT BALANCING

The current equalization with up to four HSF 600W, 1200W or 1500W units in parallel should be within 20 to 90% of the total output current rating. The output voltage of any Power Supply individually must be within 2% maximum of the other power supply output voltage setting. The expected current sharing is such that the output current variation for each power supply is less than or equal to 10% of each power supply rated output current.

**N+1 Redundancy.** An N+1 system requires one additional power supply than necessary to supply the load. If one of the parallel-connected units fail, the others will continue to provide power to the load without down time.

When units are configured for N+1 parallel redundant operation, it is desirable for current to be divided equally among the paralleled supplies. When the CB (Current Balancing) lines of paralleled HSF units are connected together, the load current is forced to divide equally between all paralleled units. If one unit fails, the remaining units will continue to supply the load, and the load current will be divided equally among the remaining operating units. The failed unit is automatically isolated from the circuit by a built-in isolation diode.

For parallel operation (see Figures 2-6 or 2-8) the conditions for current equalization are:

$$\frac{\text{Maximum Voltage} - \text{Minimum Voltage}}{\text{Rated Voltage}} = 2\% \quad \text{variation of output voltage in each power supply}$$

The maximum output current: Rated output current of each power supply x (number of power supplies) x (20 to 90 percent).

Variation of output current < ±10 % of each rated output current

To control the output from a single power supply without adjusting each one individually to within 2%, refer to PAR. 2.4.2.2 and Figure 2-6.

#### 2.4.2.5 SENSE CONNECTIONS FOR PARALLEL CONFIGURATIONS (HSF 600W MODULES ONLY)

NOTE: HSF 600W power supply sense lines **MUST** be connected to the respective output terminals; otherwise the power supplies will not work.

For parallel configurations the sense lines must be connected in parallel. This can be accomplished either by using the DIP switches (positions 3 and 4 set to ON) or by setting the DIP switch positions 3 and 4 to OFF and using external wires. When configuring units to work in parallel, the current share bus (PAR. 2.4.2.3 and 2.4.2.4) must also be configured.

For local sensing (at the rack adapter) connect the sense lines in parallel using either the DIP switches or external wires, then connect one +S and one –S from the I/O mating connector to the (+) and (-) Output terminals or the corresponding terminals on the bus bars (see Table 1-2) using short jumpers.

For remote sensing (at the load) connect the sense lines in parallel using either the DIP switches or external jumpers to connect the sense lines in parallel, then connect one +S and one –S from the I/O connector to the load using external wires.

For both local and remote sensing Positions 1 and 2 of *each* DIP switch in the parallel configuration must be set to OFF (open); refer to Figure 1-3 to identify the DIP switch associated with a corresponding slot.

See the following paragraphs for more details:

- PAR. 2.4.2.5.1: Parallel configurations using DIP switches to connect the sense lines in parallel and external wires to configure local or remote sensing.
- PAR. 2.4.2.5.2: Parallel configurations using external wires to connect the sense lines in parallel and external wires to configure local or remote sensing.

#### **2.4.2.5.1 PARALLEL CONFIGURATION USING DIP SWITCHES TO CONNECT SENSE LINES IN PARALLEL**

Figure 2-9 is a simplified diagram of a typical parallel configuration using local sensing via external wires to connect V(+) to S(+), V(-) to S(-) and DIP switch settings to connect the sense leads in parallel. This configuration requires the following:

1. For each supply in parallel set DIP switch positions 1 and 2 to OFF (open).
2. For each DIP switch between parallel-connected slots (DIP 2), set DIP switch positions 3 and 4 to ON (closed) to connect sense leads in parallel.
3. For each DIP switch between parallel-connected slots configure position 5 to connect the current share bus by referring to PAR. 2.4.2.3 and 2.4.2.4).
4. Configure Positions 6, 7, and 8 (alarms) of each DIP switch per PAR. 2.5.
5. For local sensing connect wire between one I/O mating connector pin 3 (S+) or Euro Mating plug (S+) and corresponding power supply (+) output terminal or bus bar. For remote sensing connect wire between one I/O mating connector pin 3 (S+) or Euro Mating plug (S+) and corresponding load (+) terminal.
6. For local sensing connect wire between one I/O mating connector pin 11 (S-) or Euro Mating plug (S-) and corresponding power supply (-) output terminal or bus bar. For remote sensing connect wire between one I/O mating connector pin 11 (S-) or Euro Mating plug (S-) and corresponding load (-) terminal.

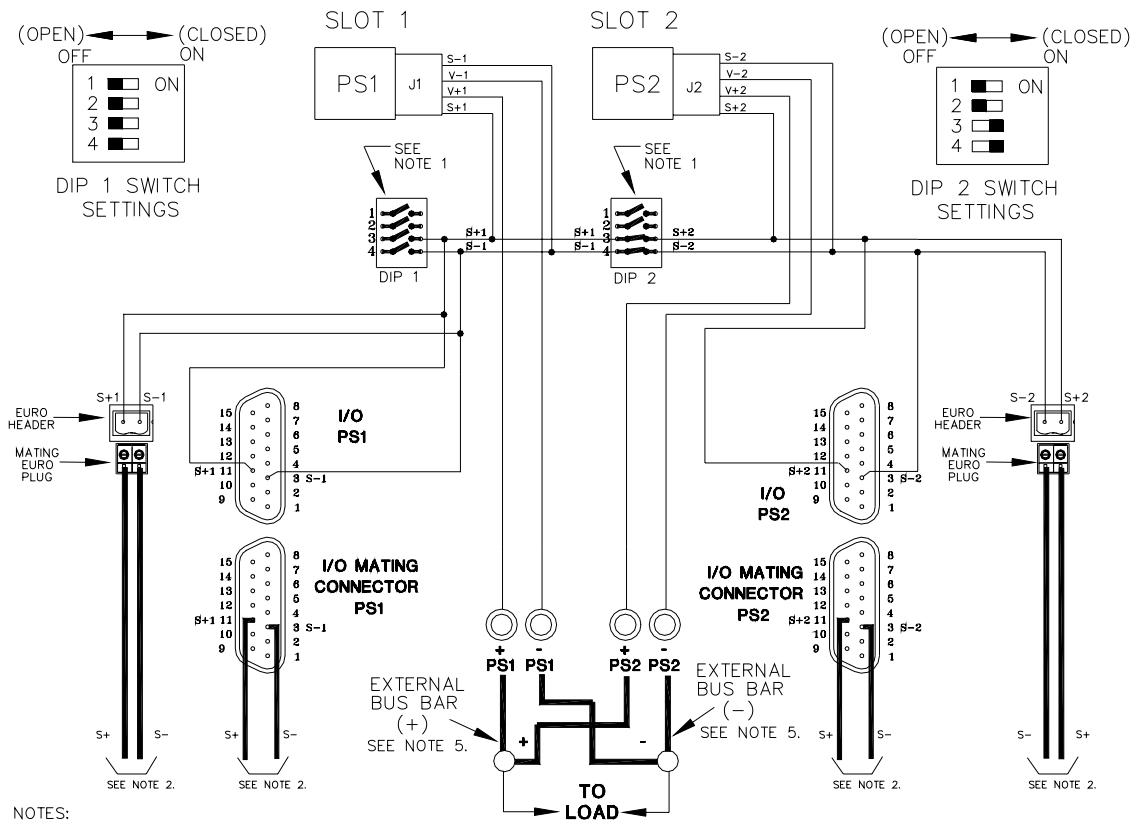

NOTES:

1. DIP SWITCH SETTINGS FOR PARALLEL OPERATION :
  - POSITIONS 1 AND 2 OF DIP SWITCHES 1 AND 2 MUST BE SET TO OFF (OPEN).
  - POSITIONS 3 AND 4 OF DIP SWITCH 2 MUST BE SET TO ON (CLOSED).
  - POSITIONS 3 AND 4 OF DIP SWITCH 1 ARE NOT CONNECTED, THEIR SETTING IS IRRELEVANT.
2. CONNECT ONLY ONE PAIR OF SENSE LINES (S+, S-) TO EITHER THE (+) AND (-) BUS BAR TERMINALS, RESPECTIVELY, FOR LOCAL SENSING OR TO THE LOAD FOR REMOTE SENSING. SENSE LINE CONNECTIONS MAY FROM EITHER THE I/O MATING CONNECTOR SENSE PINS OR FROM EURO HEADER PINS.
3. CONNECTIONS TO I/O CONNECTORS, EURO HEADERS AND DIP SWITCHES ARE INTERNAL AND SHOWN FOR REFERENCE ONLY.
4. I/O MATING CONNECTOR VIEWED FROM FRONT (MATING FACE) FOR EASE OF LOCATING CORRESPONDING I/O CONNECTOR PINS.
5. FOR PARALLEL CONNECTIONS, DO NOT DAISY CHAIN DC OUTPUTS; CONNECT INDIVIDUAL + AND - OUTPUTS TO THE LOAD.

3042912

**FIGURE 2-9. TYPICAL PARALLEL CONNECTIONS USING EXTERNAL WIRES FOR LOCAL/REMOTE SENSING AND DIP SWITCHES TO PARALLEL SENSE WIRES (HSF 600W ONLY)**

#### **2.4.2.5.2 PARALLEL CONFIGURATIONS USING EXTERNAL WIRES TO CONNECT SENSE LINES IN PARALLEL (HSF 600W ONLY)**

Figure 2-10 is a simplified diagram of a typical parallel configuration using local or remote sensing via external wires to connect V(+) to S(+), V(-) to S(-) and wires connected to the I/O mating connector to connect the sense leads in parallel. This configuration requires the following:

1. For each supply in parallel set DIP switch positions 1 and 2 to OFF (open).
2. For each DIP switch between parallel-connected slots (DIP 2 in Figure 2-10), set DIP switch positions 3 and 4 to OFF (open) (sense leads will be connected in parallel in steps 5 and 6).
3. For each DIP switch between parallel-connected slots configure position 5 to connect the current share bus by referring to PAR. 2.4.2.3 and 2.4.2.4.
4. Configure Positions 6, 7, and 8 (alarms) of each DIP switch per PAR. 2.5.
5. Connect Sense (+) lines in parallel by connecting wires between pin 3 of each I/O mating connector or between the S+ terminals of the Euro mating plug.
6. Connect Sense (-) lines in parallel by connecting wires between pin 11 of each I/O mating connector or between the S- terminals of the Euro mating plug.
7. For local sensing connect wire between one I/O mating connector pin 3 (S+) or Euro Mating plug (S+) and corresponding power supply (+) output terminal or bus bar. For remote sensing connect wire between one I/O mating connector pin 3 (S+) or Euro Mating plug (S+) and corresponding load (+) terminal.
8. For local sensing connect wire between one I/O mating connector pin 11 (S-) or Euro Mating plug (S-) and corresponding power supply (-) output terminal or bus bar. For remote sensing connect wire between one I/O mating connector pin 11 (S-) or Euro Mating plug (S-) and corresponding load (-) terminal.



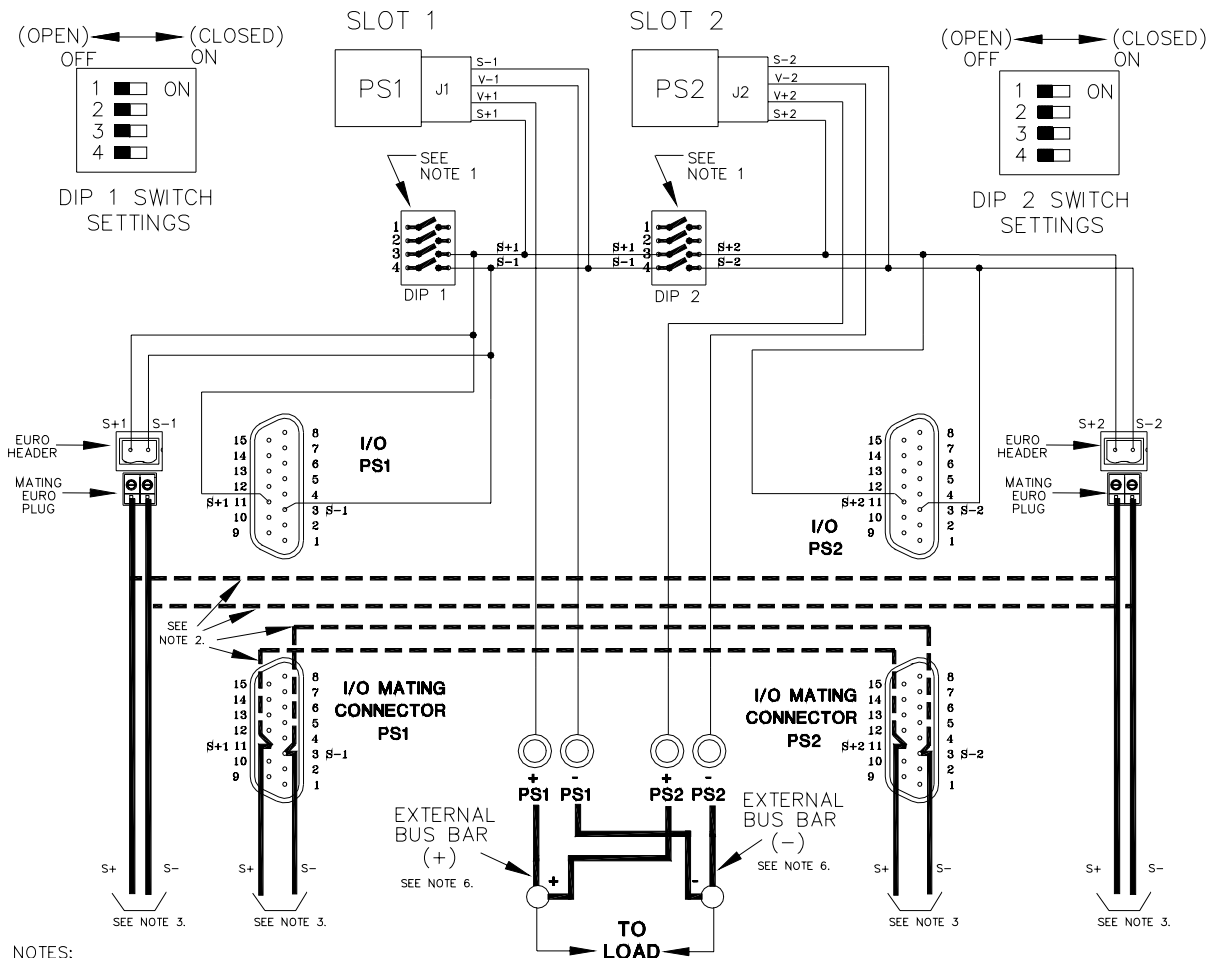

NOTES:

1. DIP SWITCH SETTINGS FOR PARALLEL OPERATION :
  - POSITIONS 1 AND 2 OF DIP SWITCHES 1 AND 2 MUST BE SET TO OFF (OPEN).
  - POSITIONS 3 AND 4 OF DIP SWITCH 2 MUST BE SET TO OFF (OPEN).
  - POSITIONS 3 AND 4 OF DIP SWITCH 1 ARE NOT CONNECTED, THEIR SETTING IS IRRELEVANT.
2. PARALLEL SENSE LINES BY CONNECTING S+ AND S- AS SHOWN, USING EITHER THE MATING I/O CONNECTOR OR THE MATING EURO PLUG.
3. CONNECT ONLY ONE PAIR OF SENSE LINES (S+, S-) TO EITHER THE (+) AND (-) BUS BAR TERMINALS, RESPECTIVELY, FOR LOCAL SENSING OR TO THE LOAD FOR REMOTE SENSING. CONNECTIONS MUST BE FROM THE SAME CONNECTOR USED TO PARALLEL THE CONNECTIONS, EITHER THE MATING I/O CONNECTOR OR THE MATING EURO PLUG.
4. CONNECTIONS TO I/O CONNECTORS, EURO HEADERS AND DIP SWITCHES ARE INTERNAL AND SHOWN FOR REFERENCE ONLY.
5. I/O MATING CONNECTOR VIEWED FROM FRONT (MATING FACE) FOR EASE OF LOCATING CORRESPONDING I/O CONNECTOR PINS.
6. FOR PARALLEL CONNECTIONS, DO NOT DAISY CHAIN DC OUTPUTS; CONNECT INDIVIDUAL + AND - OUTPUTS TO THE LOAD.

3042913

**FIGURE 2-10. TYPICAL PARALLEL CONNECTIONS USING EXTERNAL WIRES FOR LOCAL/REMOTE SENSING AND I/O MATING CONNECTOR JUMPERS TO PARALLEL SENSE WIRES (HSF 600W ONLY)**

### 2.4.3 SERIES CONNECTION

HSF power supplies may be connected in series to obtain higher output voltages. The power supply with the lowest rated value of maximum current establishes the maximum load current allowed. Series configurations can only be accomplished by **external wiring** of the I/O mating connector.

The DC OUTPUT + terminal of one supply must be connected to DC OUTPUT – terminal of the next supply. Each Power Supply in series should be protected by a diode connected in parallel with the output as shown in Figure 2-11. The diode protects against reverse voltages. For convenience bus bars are available as accessories to make these connections when connecting adjacent slots in series (refer to Table 1-2). Protection diodes must conform to the following specifications:

- $V_{REV} > 2 \times V_{NOM} \times N$  where  $V_{NOM}$  is the output voltage of the HSF power supply (24V or 48V) and N is the number of power supplies connected in series.
- $I_{FWD} > 1.5 \times I_{NOM}$  where  $I_{NOM}$  is the output current of the HSF power supply (50A or 32A)

Rack adapter DIP switches positions 1 through 5 must be set to OFF (open) on all DIP switches between series-connected modules (refer to Figure 1-5).

Table 2-4 lists the settings for the HSF DIP switches required to configure HSF power supplies to use either local or remote control.

**TABLE 2-4. HSF DIP SWITCH CONFIGURATION FOR VOLTAGE CONTROL OF MULTIPLE UNITS IN SERIES**

| HSF DIP SWITCH POSITION<br>(See Note) | HSF 600W     |     |                 |     | HSF 1200W, 1500W |     |                 |     |
|---------------------------------------|--------------|-----|-----------------|-----|------------------|-----|-----------------|-----|
|                                       | Vadj Control |     | External R or V |     | Vadj Control     |     | External R or V |     |
|                                       | SW2          | SW1 | SW2             | SW1 | SW2              | SW1 | SW2             | SW1 |
| Position 1 (REF)                      | OFF          | ON  | ON              | OFF | OFF              | ON  | ON              | OFF |
| Position 2 (RV)                       | OFF          | ON  | ON              | OFF | OFF              | ON  | ON              | OFF |
| Position 7 (COM)                      | OFF          | OFF | ON              | OFF | OFF              | ON  | ON              | OFF |

NOTE: HSF DIP Switches are located at the rear of each HSF module; refer to appropriate HSF manual for location.

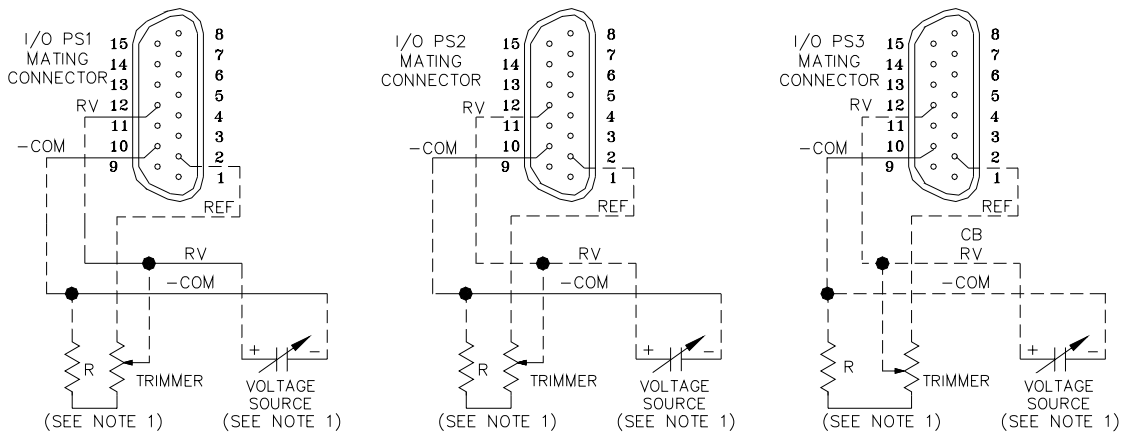
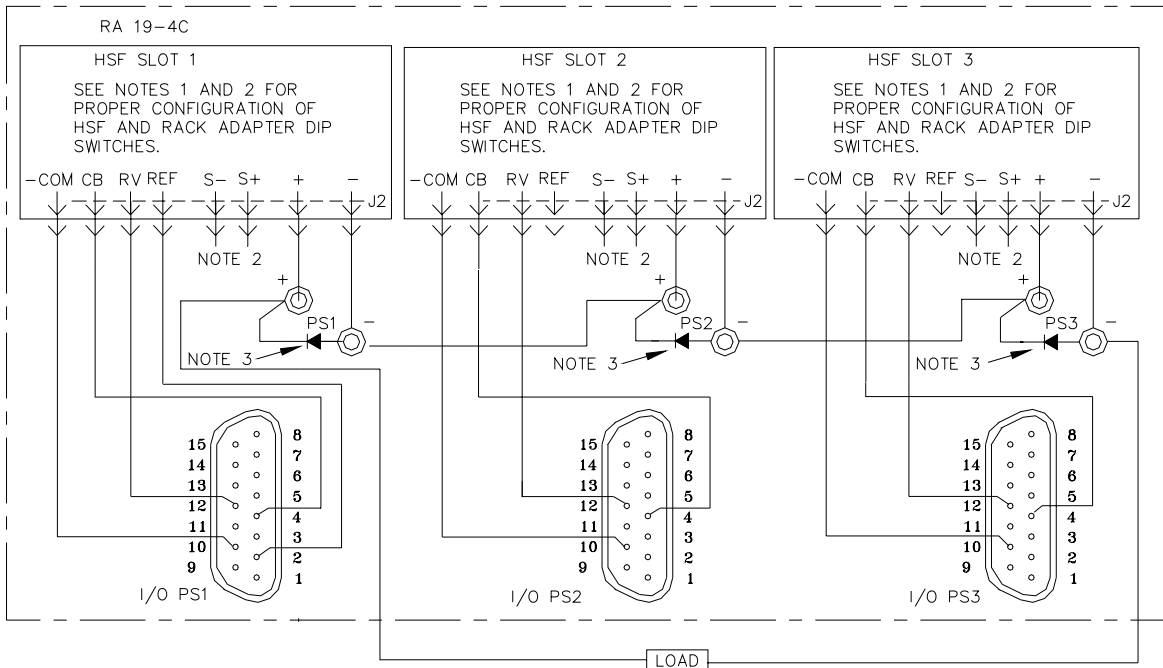

NOTES:

1. REFER TO TABLE 2-4 FOR HSF DIP SWITCH SETTINGS REQUIRED TO ALLOW OUTPUT VOLTAGE CONTROL OF ALL POWER SUPPLIES TO BE EITHER LOCAL (BY FRONT PANEL VADJ) OR REMOTE (BY EXTERNAL VOLTAGE SOURCE OR EXTERNAL RESISTANCE).
2. RACK ADAPTER DIP SWITCHES 1, 2, AND 3 MUST BE SET AS FOLLOWS:  
POSITIONS 1, 2: ON (LOCAL SENSING ENABLED)  
POSITIONS 3, 4, 5, 9 AND 10: OFF
3. PROTECTION DIODES ARE REQUIRED.
4. CONNECTIONS BETWEEN I/O CONNECTORS AND HSF POWER SUPPLIES ARE INTERNAL TO RACK ADAPTER AND ARE SHOWN FOR REFERENCE ONLY.

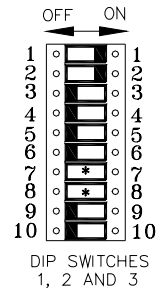

\* DEPENDS ON ALARM CONFIGURATION, SEE TABLE 2-2.

3043042

FIGURE 2-11. SERIES CONNECTION

## 2.5 ALARM CONFIGURATIONS

The HSF Power Supplies each provide a normally closed (N.C.) and normally open (N.O.) line referenced to common (COM) for use as an alarm at the users discretion. The N.C. line opens upon failure, the N.O. line closes upon failure. The RA 19-4C is configured at the factory for independent operation of these lines. It is possible to configure these alarm lines to allow multiple power supplies to provide a failure indication using the N.O. (close on failure) lines, N.C (open on failure) lines, or both. Each alarm circuit can be configured in two ways: either by rear panel DIP switches or by external wiring of the I/O mating connector.

**CAUTION: The user is responsible for ensuring that the alarm circuit does not exceed DIP switch specifications: 100mA, 50V d-c, maximum.**

### 2.5.1 N.O. ALARM LINE (CLOSE ON FAILURE)

The N.O. and COM line of each HSF supply provide a closed contact (short circuit) upon failure. To configure multiple power supplies so that a failure of any supply produces a failure indication, it is necessary to connect the N.O. lines in parallel and the COM lines in parallel. The following paragraphs describe three ways to accomplish this:

- Use the rear panel DIP switches to make the connections (PAR. 2.5.1.1).
- Use external connections from the I/O mating connectors (PAR. 2.5.1.2).
- Use external connections from the Alarm I/O terminal blocks (PAR. 2.5.1.1).

#### 2.5.1.1 CLOSE ON FAILURE USING REAR PANEL DIP SWITCHES

Close on failure for multiple power supplies can be accomplished by setting DIP switch positions 6 and 7 to ON (closed). associated with each adjacent slot included in the alarm circuit. For example, for PS1 and PS2, set DIP switch 2, positions 6 and 7 to ON (closed). The failure indication (short circuit) will be present across both N.O.1 and COM1, and N.O.2 and COM2. Figure 2-12 is a simplified diagram illustrating a close on failure alarm configuration for four power supplies using rear panel DIP switches.

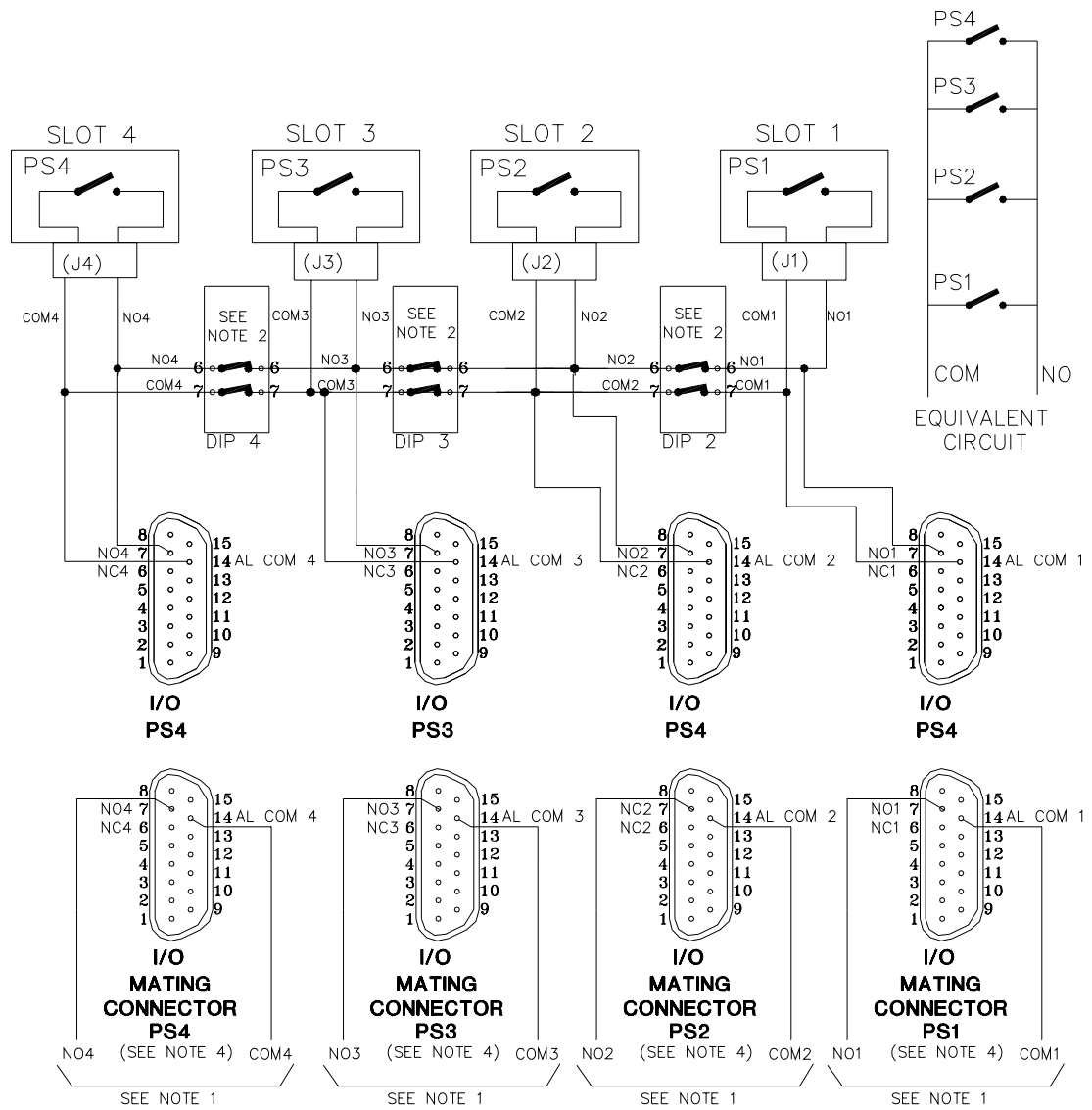

**NOTES:**

1. USE ANY PAIR OF NO() AND COM() LINES FOR CLOSE ON FAILURE ALARM.
2. SET ALL ASSOCIATED DIP SWITCHES, POSITIONS 6 AND 7, TO ON (CLOSED).
3. CONNECTIONS TO I/O CONNECTOR ARE INTERNAL AND SHOWN FOR REFERENCE ONLY.
4. I/O MATING CONNECTOR VIEWED FROM FRONT (MATING FACE) FOR EASE OF LOCATING CORRESPONDING I/O CONNECTOR PINS.

3042850

**FIGURE 2-12. TYPICAL CLOSE ON FAILURE ALARM CONFIGURATION USING REAR PANEL DIP SWITCHES WITH OUTPUT FROM I/O MATING CONNECTOR, SIMPLIFIED DIAGRAM**

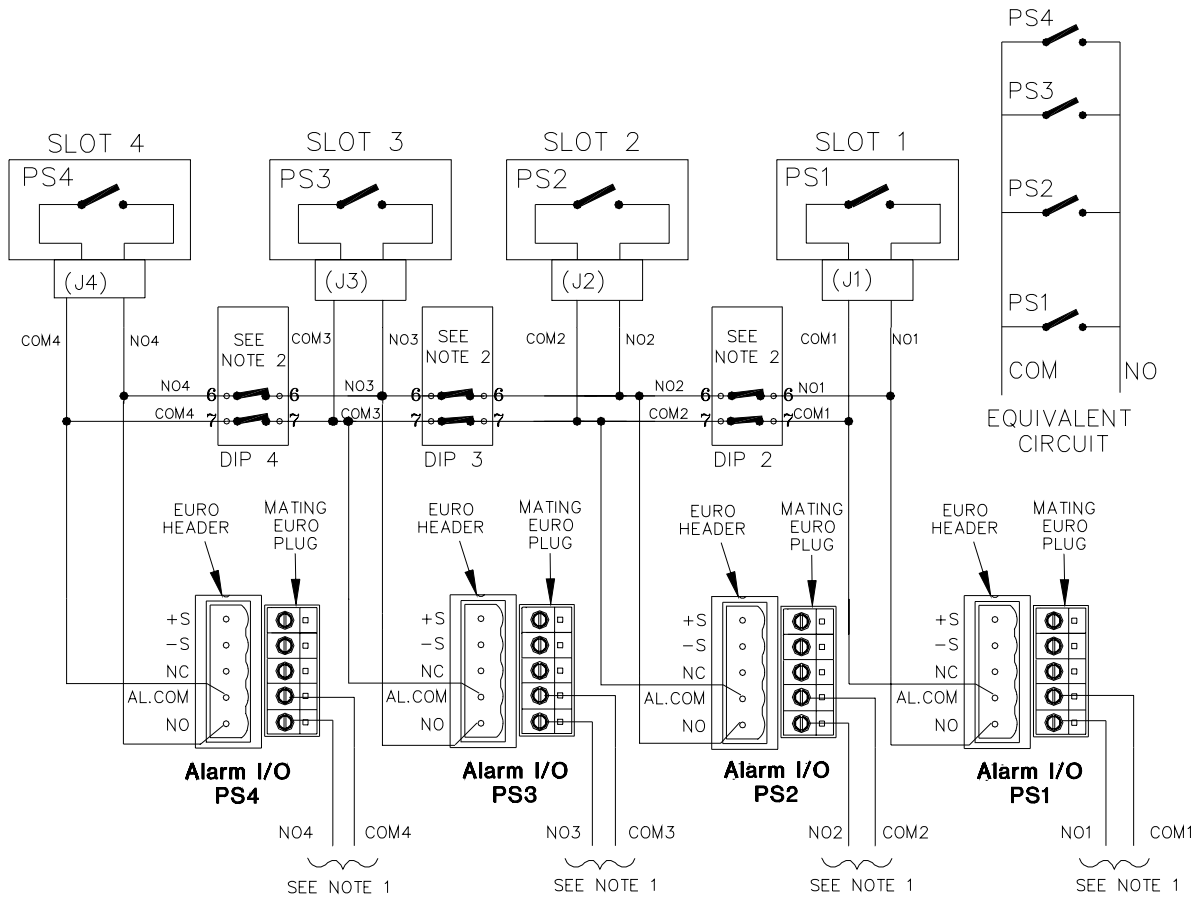

**NOTES:**

1. USE ANY PAIR OF NO() AND COM() LINES FOR CLOSE ON FAILURE ALARM.
2. SET ALL ASSOCIATED DIP SWITCHES, POSITIONS 6 AND 7, TO ON (CLOSED).
3. CONNECTIONS TO I/O CONNECTOR ARE INTERNAL AND SHOWN FOR REFERENCE ONLY.

3042901

**FIGURE 2-13. TYPICAL CLOSE ON FAILURE ALARM CONFIGURATION USING REAR PANEL DIP SWITCHES, WITH OUTPUT FROM ALARM I/O TERMINAL BLOCKS, SIMPLIFIED DIAGRAM**

### 2.5.1.2 CLOSE ON FAILURE USING EXTERNAL WIRING AT I/O MATING CONNECTOR

Close on failure for multiple power supplies can be accomplished by wiring N.O. and COM in parallel at the I/O mating connector. DIP switches associated with slots included in the alarm circuit must have positions 6 and 7 set to OFF (open). The failure indication (short circuit) will be present across any pair of N.O. and COM lines. Figure 2-14 is a simplified diagram illustrating a close on failure alarm configuration for four power supplies using external wiring at the I/O mating connector.

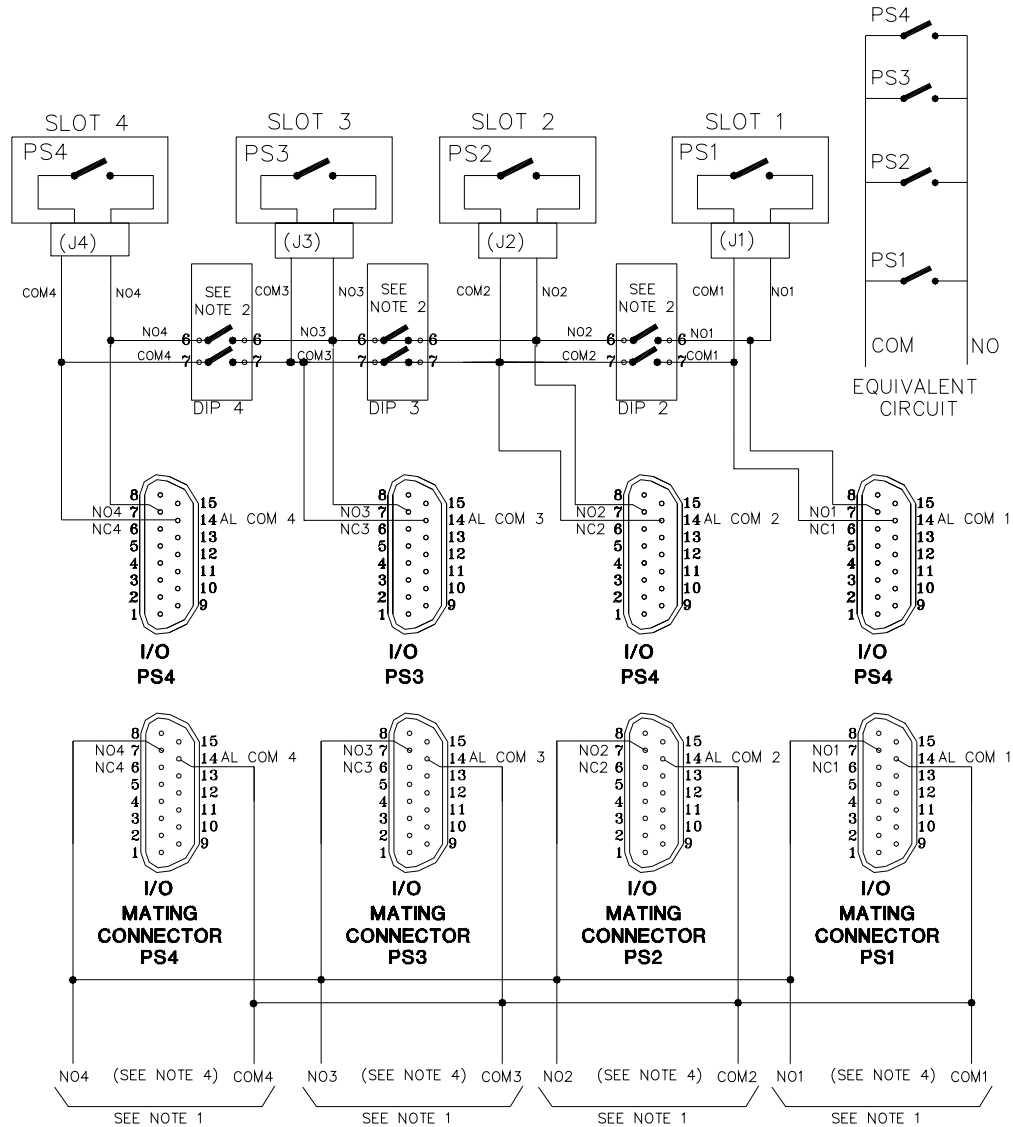

#### NOTES:

1. USE ANY PAIR OF NO() AND COM() LINES FOR CLOSE ON FAILURE ALARM.
2. SET ALL ASSOCIATED DIP SWITCHES, POSITIONS 6 AND 7, TO ON (CLOSED).
3. CONNECTIONS TO I/O CONNECTOR ARE INTERNAL AND SHOWN FOR REFERENCE ONLY.
4. I/O MATING CONNECTOR VIEWED FROM FRONT (MATING FACE) FOR EASE OF LOCATING CORRESPONDING I/O CONNECTOR PINS.

3042851

**FIGURE 2-14. CLOSE ON FAILURE ALARM CONFIGURATION USING EXTERNAL WIRING AT I/O MATING CONNECTOR, SIMPLIFIED DIAGRAM**

### 2.5.1.3 CLOSE ON FAILURE USING EXTERNAL WIRING AT ALARM I/O TERMINAL BLOCK

Close on failure for multiple power supplies can be accomplished by wiring N.O. and COM in parallel at the Alarm I/O terminal block. DIP switches associated with slots included in the alarm circuit must have positions 6 and 7 set to OFF (open). The failure indication (short circuit) will be present across any pair of N.O. and COM lines. Figure 2-15 shows a close on failure alarm configuration for four power supplies using external wiring at the Alarm I/O terminal blocks.

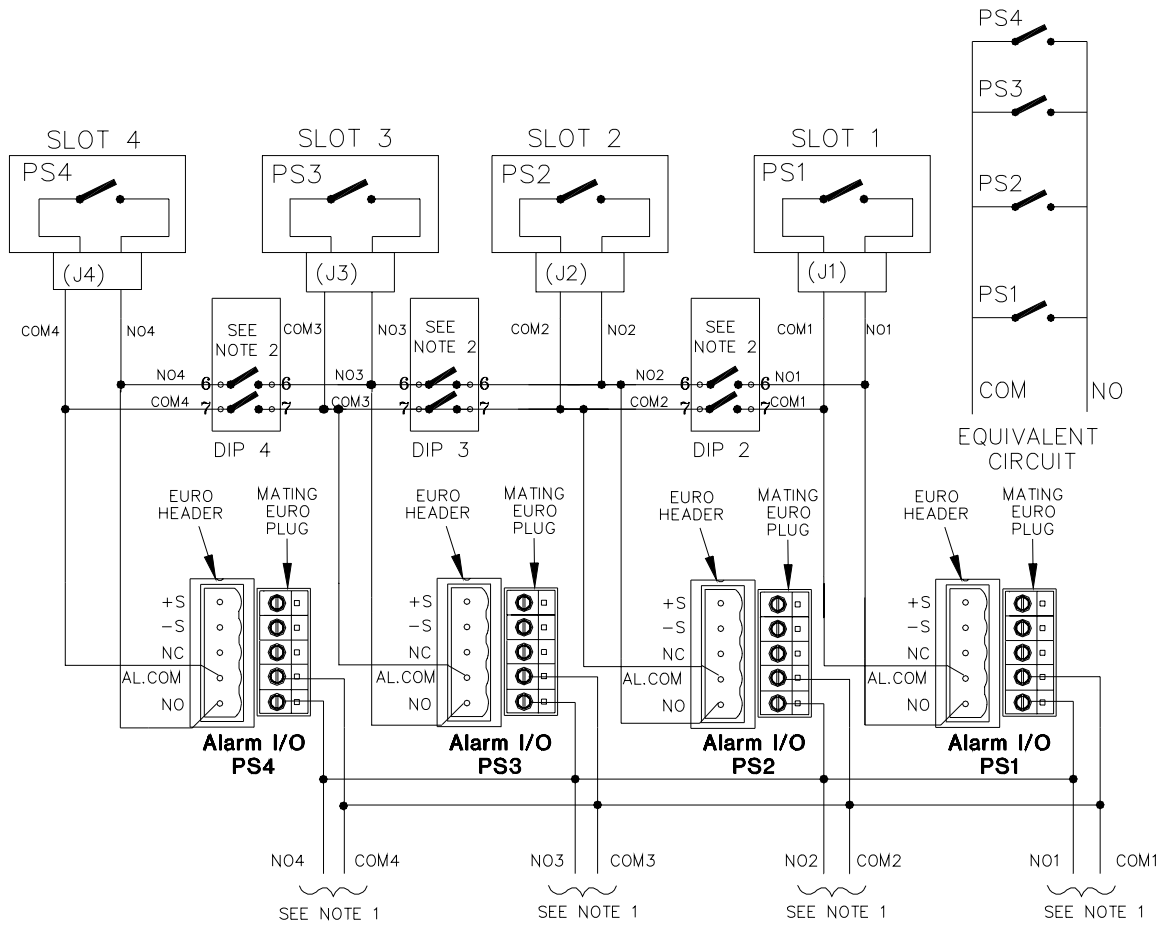

3042890

- NOTES:
1. USE ANY PAIR OF NO() AND COM() LINES FOR CLOSE ON FAILURE ALARM.
  2. SET ALL ASSOCIATED DIP SWITCHES, POSITIONS 6 AND 7, TO ON (CLOSED).
  3. CONNECTIONS TO EURO HEADER ARE INTERNAL AND SHOWN FOR REFERENCE ONLY.

**FIGURE 2-15. CLOSE ON FAILURE ALARM CONFIGURATION USING EXTERNAL WIRING AT ALARM I/O TERMINAL BLOCK, SIMPLIFIED DIAGRAM**

### 2.5.2 N.C. ALARM LINE (OPEN ON FAILURE)

The N.C and COM line of each HSF supply provide an open contact (open circuit) upon failure. To configure multiple power supplies so that a failure of any supply produces a failure indication, it is necessary to connect the N.C. line with the COM line of the next power supply, so the alarm line is connected in series.



### 2.5.2.1 OPEN ON FAILURE USING REAR PANEL DIP SWITCHES

The open on failure alarm for multiple power supplies is accomplished by setting the associated DIP switch, position 8, to ON (closed) for each slot included in the alarm circuit as indicated in Figure 2-16. Setting DIP switch position 8 to ON (closed) connects the N.C. line to the COM line of the adjacent power supply. Figure 2-16 illustrates an open on failure alarm configuration for four power supplies where the alarm connections are made through the rear panel DIP switches and the alarm signals are applied to the user's alarm circuit via the I/O connector. Figure 2-17 is the same, except alarm signals are available at the Alarm I/O Terminal Blocks.

**CAUTION: The user is responsible for ensuring that the alarm circuit does not exceed DIP switch specifications: 100mA, 50V d-c, maximum.**

To configure PS1, PS2, PS3 and PS4 as open on failure, set position 8 of DIP switches DIP 2, DIP 3, and DIP 4 to ON (closed). The failure indication (open circuit) will be present across N.C.4 and COM 1.

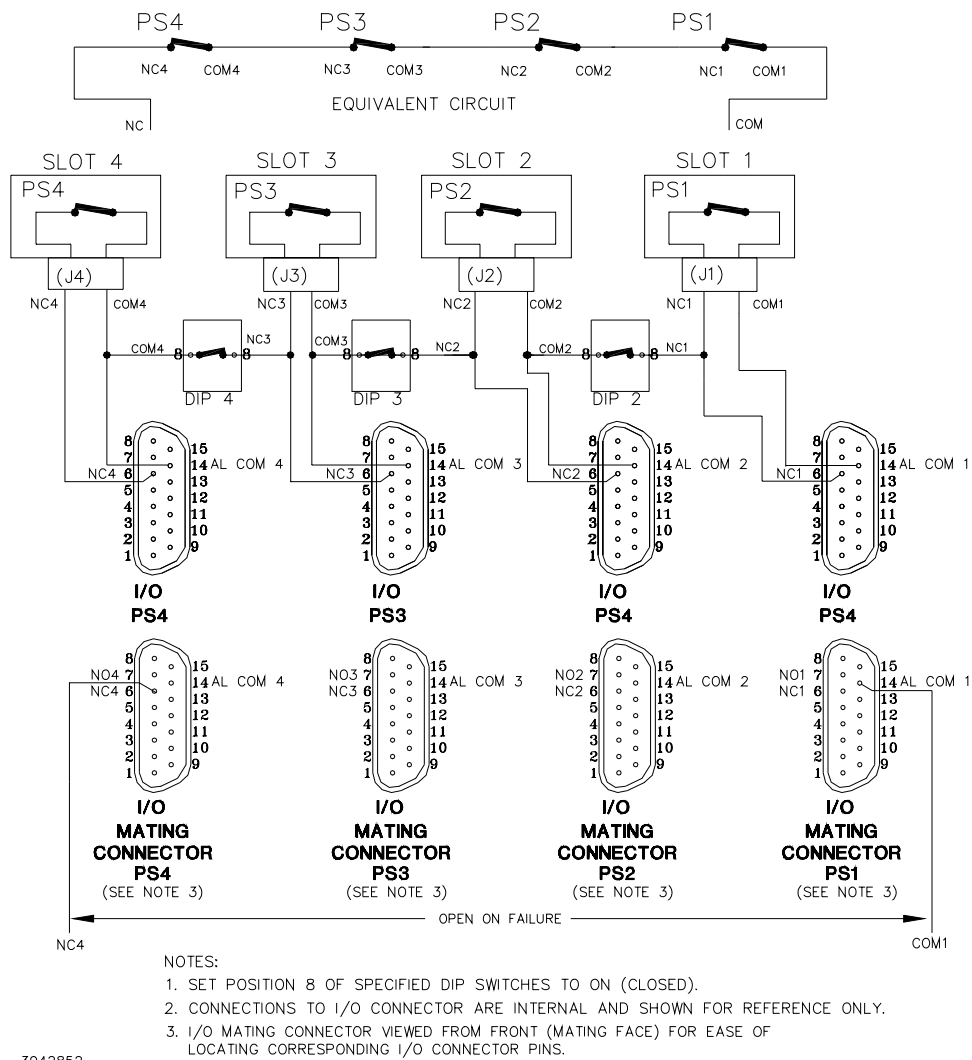

**FIGURE 2-16. TYPICAL OPEN ON FAILURE ALARM CONFIGURATION USING REAR PANEL DIP SWITCHES WITH OUTPUT FROM I/O MATING CONNECTOR, SIMPLIFIED DIAGRAM**

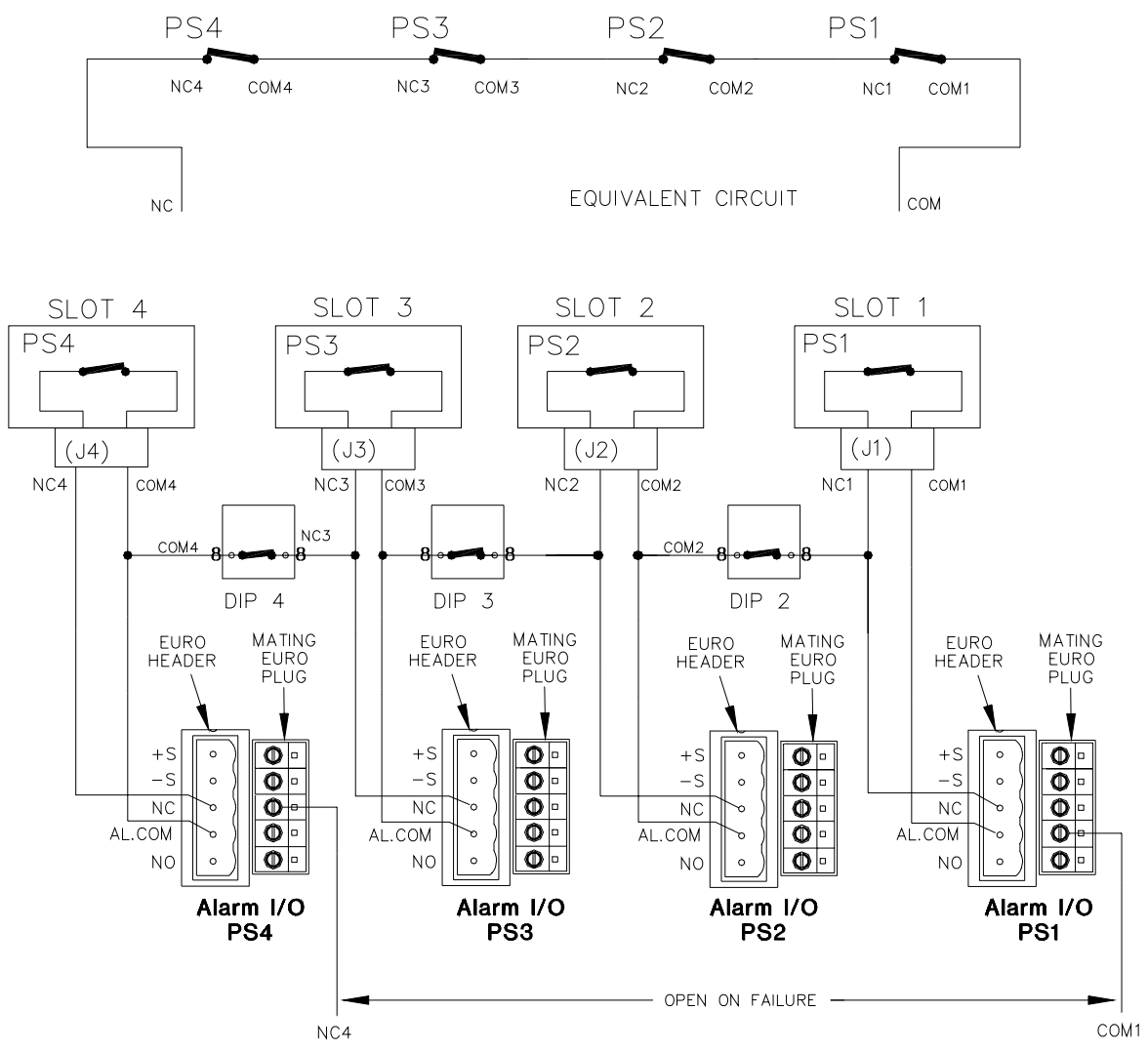

- NOTES:
1. SET POSITION 8 OF SPECIFIED DIP SWITCHES TO ON (CLOSED).
  2. CONNECTIONS FROM I/O CONNECTORS AND DIP SWITCHES TO ALARM I/O TERMINAL BLOCKS ARE INTERNAL AND SHOWN FOR REFERENCE ONLY.

3042902

**FIGURE 2-17. TYPICAL OPEN ON FAILURE ALARM CONFIGURATION USING REAR PANEL DIP SWITCHES WITH OUTPUT FROM ALARM I/O TERMINAL BLOCKS, SIMPLIFIED DIAGRAM**

### 2.5.2.2 OPEN ON FAILURE USING EXTERNAL WIRING OF I/O MATING CONNECTOR

Figure 2-18 illustrates an open on failure alarm configuration using external wiring of the I/O mating connectors for four power supplies. It is necessary to set DIP switch position 8 to OFF (open) for each slot included in the open on failure alarm circuit.

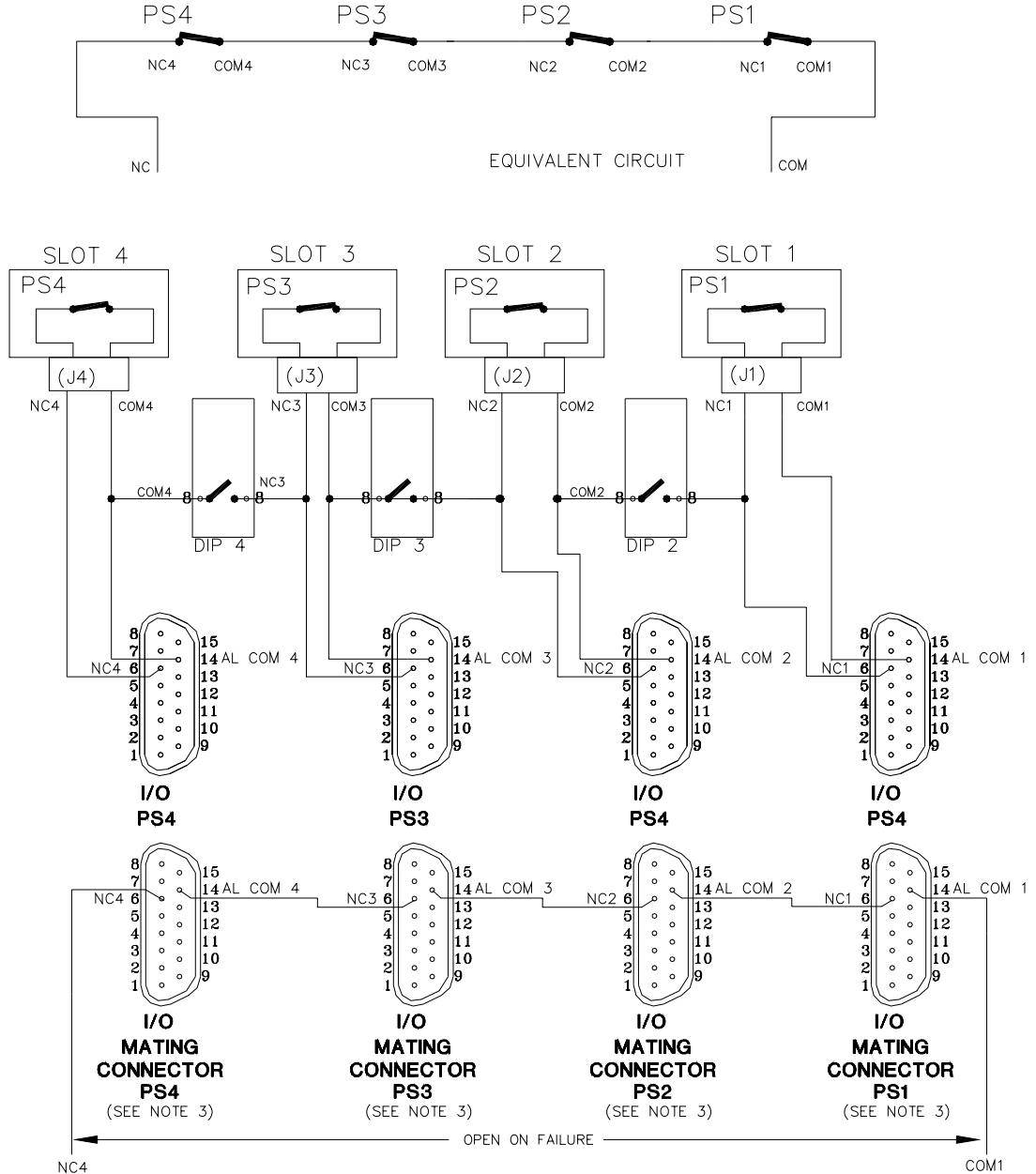

**NOTES:**

1. SET POSITION 8 OF SPECIFIED DIP SWITCHES TO ON (CLOSED).
2. CONNECTIONS TO I/O CONNECTOR ARE INTERNAL AND SHOWN FOR REFERENCE ONLY.
3. I/O MATING CONNECTOR VIEWED FROM FRONT (MATING FACE) FOR EASE OF LOCATING CORRESPONDING I/O CONNECTOR PINS.

3042853

**FIGURE 2-18. OPEN ON FAILURE ALARM CONFIGURATION USING EXTERNAL WIRING AT I/O MATING CONNECTOR, SIMPLIFIED DIAGRAM**

### 2.5.2.3 OPEN ON FAILURE USING EXTERNAL WIRING OF I/O ALARM TERMINAL BLOCKS

Figure 2-18 illustrates an open on failure alarm configuration using external wiring of the I/O mating connectors for four power supplies. It is necessary to set DIP switch position 8 to OFF (open) for each slot included in the open on failure alarm circuit.

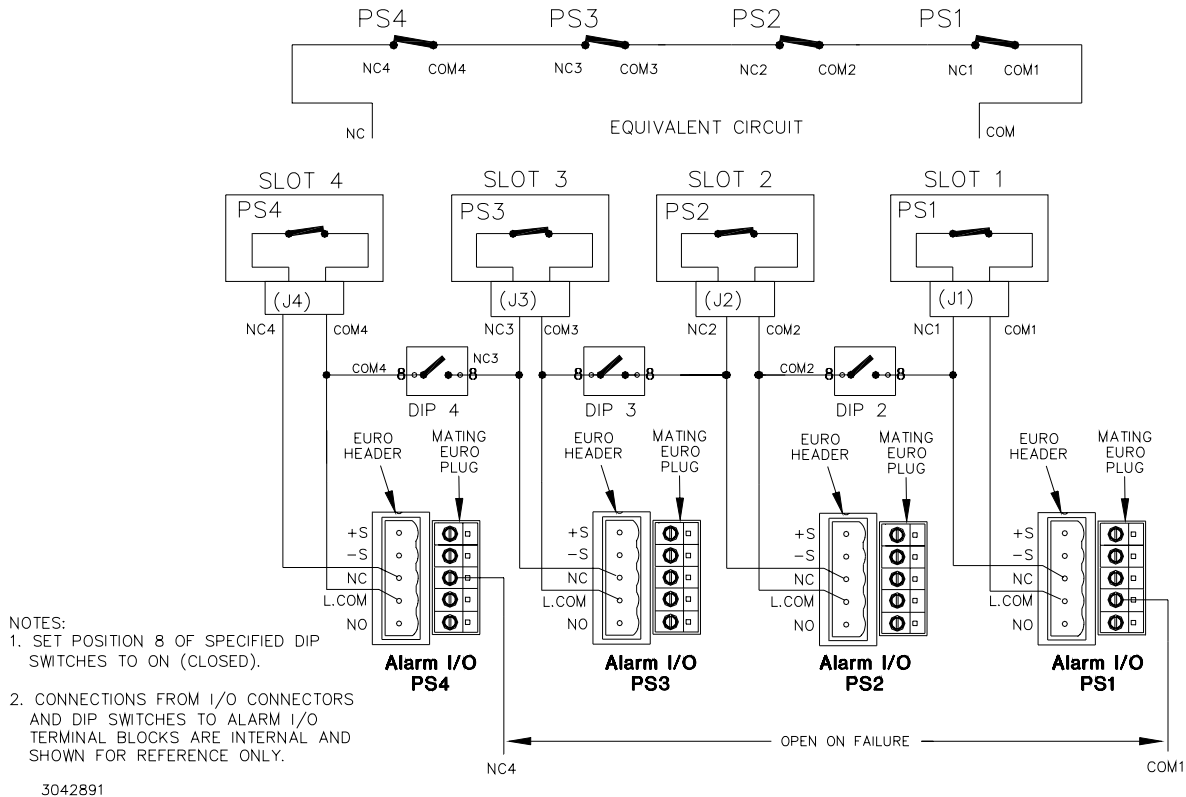

**FIGURE 2-19. OPEN ON FAILURE ALARM CONFIGURATION USING EXTERNAL WIRING AT I/O ALARM TERMINAL BLOCKS, SIMPLIFIED DIAGRAM**

## 2.6 TERMINATIONS

All input, output and control terminations are located on the rear panel of the rack adapter (see Figure 1-4).

## 2.7 COOLING

The HSF power supplies installed in the rack adapter are maintained within their operating temperature range by means of cooling fans within the power supplies. ALL OPENINGS AROUND THE RACK ADAPTER CASE MUST BE KEPT CLEAR OF OBSTRUCTION TO ENSURE PROPER AIR CIRCULATION. Care must be taken that the ambient temperature, which is the temperature of the air immediately surrounding the rack adapter, does not rise above the specified limits for the operating load conditions of the installed HSF power supplies. Kepco recommends providing additional space above and below the rack adapter where possible when the rack adapter is fully populated.

## 2.8 INSTALLATION (Refer to "Mechanical Outline Drawing," Figure 1-6.)

The rack adapter mounts directly to EIA-RS 310D standard 19" racks via the two mounting ears; two screws are required per mounting ear for proper support.

### CAUTION

#### RACK ADAPTER SHOULD BE MOUNTED BEFORE INSTALLING POWER SUPPLIES.

Provide adequate clearance around case and ensure that the temperature immediately surrounding the unit does not exceed the maximum specified ambient temperature for the operating conditions of the installed power supplies. For severe shock or vibration environments, see NOTE to PAR. 2.9 below.

### 2.8.1 INSTALLING OPTIONAL PROTECTIVE COVER (Refer to Figure 2-20.)

A clear plastic cover (Kepco P/N 137-0145) is available as an accessory to protect the rear terminals against accidental contact. Four standoffs (minimum) (Kepco P/N 104-0385) are required for installation.

1. Remove screws and cable clamps as necessary from mounting points "A" (see Figure 2-20). A minimum of four standoffs must be installed. Save all screws and clamps removed.
2. Choose standoff locations to accommodate cable routing and install standoffs at mounting points A (Figure 2-20). Use of suitable thread-lock adhesive on standoff threads is recommended. If cable clamps need to be reused, use standoff to secure clamp to backplate.
3. Insert ten protective cover tabs (three each at top and bottom and two at each side) into corresponding backplate slots. Rectangular cutouts are provided at the edge of the protective cover for cable exit. Round (9/16 in. diameter) holes are provided for strain relief/cable saddle clamps.
4. Secure protective cover to standoffs using screws removed in step 1.

### 2.8.2 INSTALLING OPTIONAL BUS BAR.

Bus bars which connect output terminals for parallel or series operation are available as accessories (see Table 1-2).

1. Remove and save the hex screw and washer from each output terminal to be connected together (bus bars can only be connected to terminals of adjacent slots).
2. Install bus bar across applicable terminals and secure it as shown with the previously removed hardware.
3. Connect output cables to bus bar studs using hex nut (see Table 1-2).  
**CAUTION: Ensure current does not exceed 100 Amperes per stud.**

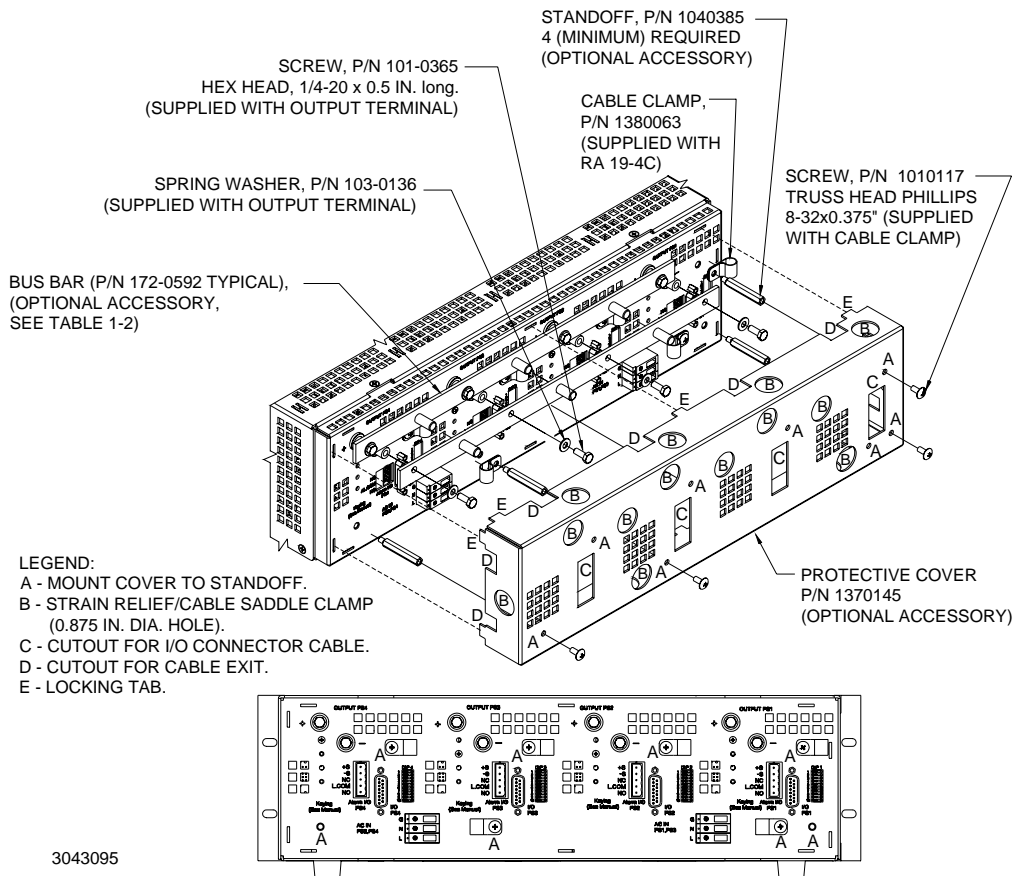

**FIGURE 2-20. OPTIONAL PROTECTIVE COVER OR BUS BAR INSTALLATION**

## 2.9 INSTALLING HSF POWER SUPPLIES

HSF 600W, 1200W and 1500W power supplies are provided with two (2) retention latches located at each side of the bottom edge of the front panel (see Figure 1-2). These latches work in conjunction with the RA 19-4C rack adapter to prevent unauthorized or inadvertent module extraction from an operating power system.

Each latch is engaged by loosening the cap-head screw approximately 1/2 turn CCW (use 5/32" hex key) and sliding the latch down to the bottom of the slot, then retightening the cap-head screw CW until snug. **DO NOT OVERTIGHTEN!** To release, follow the same procedure, except lift the latch to the top of the slot. Be sure to move the latch completely up or down to ensure full engagement and disengagement of the latching mechanism. When the HSF power supply is not installed in its plug-in rack adapter, it is recommended that the latch be secured in the open (up) position to prevent damage.

Refer to Figure 1-1, for proper slot positions applicable to the RA 19-4C Rack Adapter. With the retaining latches disengaged (at the top of the slot) as described above, insert HSF power supply in selected slot until power supply front panel is flush with rack adapter chassis, then secure the retaining latches as described above.

**NOTE:** Retaining latches must *not* be used to secure the HSF power supply in the rack adapter for shipping purposes.

The rack adapter is supplied with six cable clamps equipped with release levers that can be snapped into holes provided in the rear panel (see Figure 1-4) to support the weight of the input, output and signal cables.

NOTE: For severe shock and vibration environments each HSF module must be secured to the rack adapter with four screws screw, P/N 101-0486 (flat head, M4, 82° undercut) through the top of the rack adapter chassis and two screws screw, P/N 101-0491 (flat head, 6-32, 1/2 in. lg., 100° CSK) through the bottom of the rack adapter chassis. **Do not overtighten these screws: max. torque is 10 in.-lbs (1.1N x m)**; side support for the populated rack adapter may also be required.

## 2.10 REMOVING HSF POWER SUPPLIES



**Removal of an HSF power supply from a “live” system must be done only by authorized service personnel after HSF power switch is set to OFF. Dangerous voltages may be accessible through the open slot after a power supply is removed.**

Set the POWER ON/OFF switch to off, then loosen the two retaining latches (see PAR. 2.9) and pull the HSF power supply out of the rack adapter. Refer to PAR. 2.9 for replacement.

## 2.11 WIRING INSTRUCTIONS

Interconnections between an a-c power source and a stabilized power supply, and between the power supply and its load are as critical as the interface between other types of electronic equipment. If optimum performance is expected, certain rules for the interconnection of source, power supply and load must be observed by the user. These rules are described in detail in the following paragraphs and in the operating instructions for HSF Series power supplies.

### 2.11.1 SAFETY GROUNDING

Local, national and international safety rules dictate the grounding of the metal cover and case of any instrument connected to the a-c power source, when such grounding is an intrinsic part of the safety aspect of the instrument. The instructions below suggest wiring methods which comply with these safety requirements; however, in the event that the specific installation for the power system involves differences with the recommended wiring, it is the customer's responsibility to ensure that all applicable electric codes for safety grounding requirements are met.

### 2.11.2 SOURCE POWER CONNECTIONS

The RA 19-4C rack adapter is designed to be used in conjunction with Kepco HSF series power supplies. Source power requirements are determined by the HSF power supply (see HSF power supply Instruction Manual); no adjustment or modification of the rack adapter is required.

Source power is applied to two 3-terminal terminal blocks at the rear panel and distributed as indicated in Figure 1-3. Slots 1 and 3 are powered from one terminal block, slots 2 and 4 are powered from the other. When each terminal block receives power from a separate source, input redundancy for adjacent pairs of power supplies is achieved.

## CAUTION

### DO NOT EXCEED MAXIMUM TERMINAL BLOCK RATING OF 500V AT 36A.

Source power can also be custom configured via jumpers on the internal PC board, e.g., all slots can be powered from a single terminal block, or slots 1 and 2 can be powered from one terminal block and slots 3 and 4 from the other. Contact Kepco Applications Engineering for further details.

## CAUTION

### THE RA 19-4C DOES NOT INCORPORATE ANY SAFETY INTERRUPT DEVICES. PROTECTION OF INPUT WIRING REQUIRES USER-CONFIGURED SAFETY INTERRUPTS.

Wires must be sized according to expected current. Wire size range for each terminal block is AWG 20-10/IEC, rigid: 0.5 - 6mm<sup>2</sup>, or flexible (stranded): 0.5 - 4mm<sup>2</sup>; torque to 6 lb-in (0.6 N•M) maximum. The terminals are labeled L, N, and G. Their functions are:

- **Terminal G (Ground)** is the safety ground connection for the RA 19-4C. It is connected to the RA 19-4C chassis and to the safety ground terminal of the input power connector for each of the power supply mounting positions via the PCB backplane. Terminal G must be connected to safety ground in order to ensure proper grounding of the HSF power supplies.
- **Terminals L (Line Phase) and N (Neutral)** are connected to the input power entry connectors. Source power is provided to the power supplies indicated by the label on the rear panel. The source power connectors are independent of each other, allowing the user complete flexibility in wiring for common or redundant input power configurations.

The following standard wiring configuration is recommended by Kepco as being compliant with applicable national and international safety standards. Please consult local electrical codes for wire current ratings and other specific requirements:

- Connect Terminal G of each RA 19-4C input power terminal block to safety ground
- Connect a separate wire pair from each side of the input power to the L/N terminal pair of the input power terminal block.
- In North America where 115/230V a-c source power is used, Kepco recommends the use of a Kepco line cord (P/N 118-1145, North American style plug, 30A maximum, 6 ft. long). European applications may require the use of Kepco line cord P/N 118-1146 (250V, 32A maximum).
- Wire size is determined by the maximum rated source current for each HSF power supply and the number of power supplies installed. For lower system power configurations, smaller wire can be used; contact Kepco Applications Engineering for assistance.

#### 2.11.2.1 EMI COMPLIANCE

Depending on the application and system environment, special source power considerations may be required to meet listed Input EMI specifications for HSF power supplies, particularly FCC Class B. It may be necessary to add external source power filtering, such as installing snap-on ferrite beads on the line cord wires of the RA 19-4C as close to the input a-c terminal block as possible. Another option is to add an in-line cabinet-mounted EMI filter (available from



a number of manufacturers) between the source power and the RA 19-4C line cord. For additional assistance, contact Kepco Applications Engineering.

### 2.11.3 CONTROL SIGNAL CONNECTIONS

Access to the control signal (I/O) connector for each HSF power supply is provided via four 15-pin D-subminiature connectors on the rear panel of the rack adapter (see Figure 1-4). Four mating connectors (Kepco P/N 142-0449) are provided in a plastic bag. Consult PAR. 2.4 and the HSF operator's manual for instructions on wiring and use of these control lines.

### 2.11.4 OUTPUT LOAD CONNECTIONS

Load connections to the rack adapters are achieved via four pairs (DC OUTPUT + and –) of output terminals located on the rear panel assembly. Wire gage may be between 22 GA and 6 GA depending on ring lug used; torque to 20 lb-in (2.3 N•M) maximum. ..

#### 2.11.4.1 REDUCING RIPPLE AND NOISE

Ripple and noise are measured under nominal load conditions to provide the rated output voltage/current of the HSF power supply. Measurement of ripple/noise is illustrated in Figure 2-21. It is most important to minimize impedance between the power supply output and the load. As the length of load wires increases, ripple and noise may increase proportionally, therefore length and placement are critical for minimum ripple and noise. A filter consisting of a 50 $\mu$ F electrolytic capacitor in parallel with a 0.01 $\mu$ F capacitor must be used to eliminate unwanted ripple and noise pickup on the load wire during measurements. For noise-sensitive applications the load wires and sense wires must be twisted.

#### 2.11.4.2 PARALLEL/REDUNDANT OPERATION



**Removal of an HSF power supply from a “live” system must be done only by authorized service personnel after HSF power switch is set to OFF. Dangerous voltages may be accessible through the open slot after a power supply is removed.**

Identical HSF power supplies can be connected in parallel to provide redundant operation or increased output current to a common load. Maximum output current for each pair of the DC OUTPUT terminals is 70 Amperes. Connect the DC OUTPUT terminals of each paralleled power supply directly to the load. DO NOT DAISY CHAIN load wire conductors (See Figure 2-6).

Bus bars are available as accessories to make the connections when paralleling adjacent slots (refer to Table 1-2). When using the bus bars, the output is available from 1/4”-20 studs or perm-nuts at the busbar links. When using the bus bars, maximum output current is 140 Amperes for two paralleled units, 210 Amperes for three paralleled units, and 280 Amperes for four paralleled units.

NOTE: Verify that the current share bus lines are configured per PAR. 2.4.2.3 and 2.4.2.4.

#### 2.11.4.3 SERIES/INDEPENDENT OPERATION

The rack adapter can be used for either independent or series operation of HSF power supplies; it is factory configured for independent operation.

For series operation, connect (+) and (-) terminals at the DC OUTPUT terminal block of power supplies to be connected in series. Bus bars are available as accessories to make these connections when connecting adjacent slots in series (refer to Table 1-2). The HSF power supplies are equipped with blocking diodes which allow series operation without further modification. The RA 19-4C rack adapter is designed to safely handle a maximum output voltage of 500 Volts.

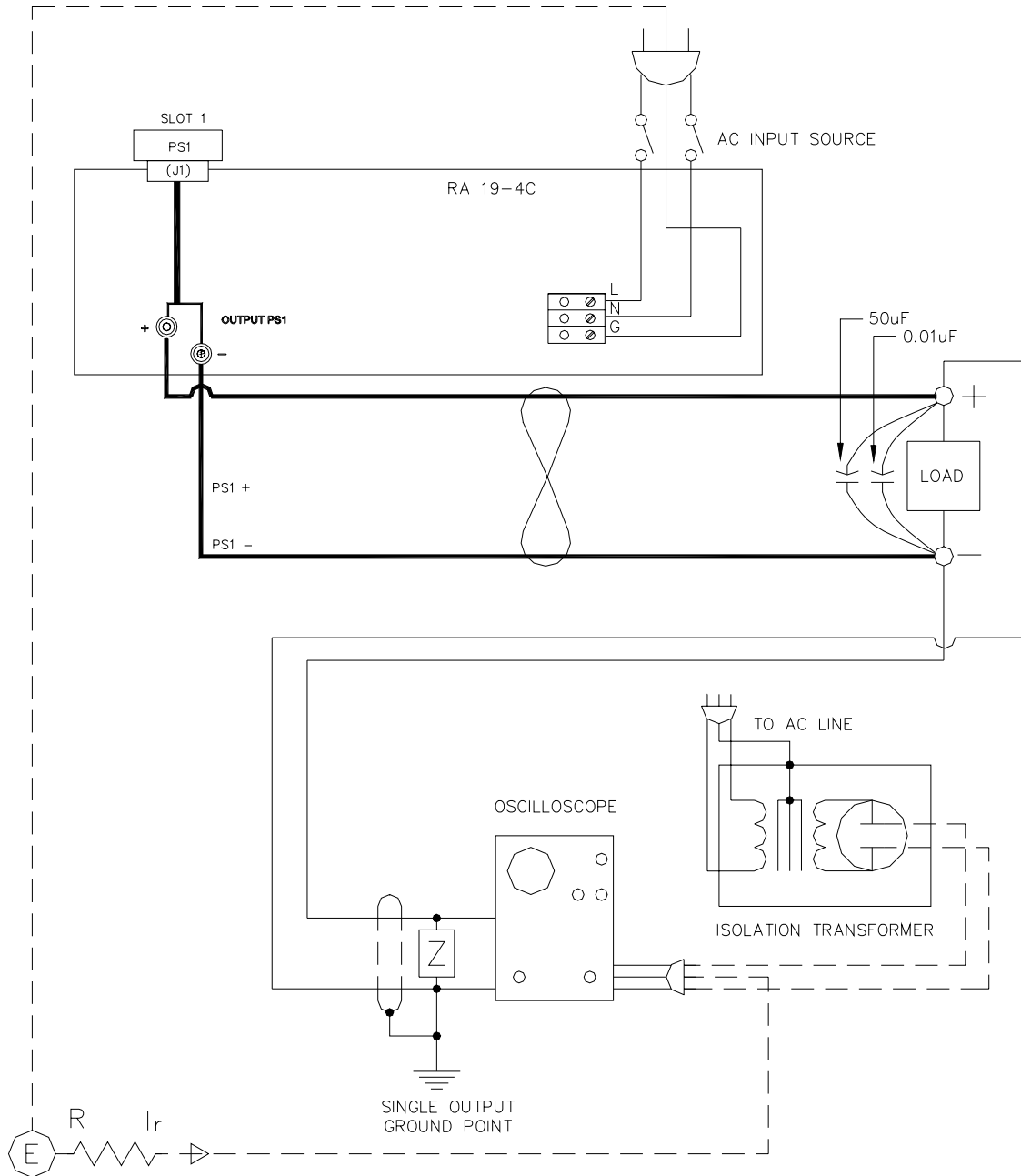

3042854

**FIGURE 2-21. RIPPLE AND NOISE MEASUREMENT SETUP DIAGRAM**

#### 2.11.4.4 MIXED OPERATION

The design of the RA 19-4C rack adapters permits the user to configure HSF power supplies for almost any combination of independent, series and parallel operation, both within a single rack adapter and between different RA 19-4C rack adapters, within the limits of the HSF operation envelope and the current and voltage ratings specified in PAR.s 2.11.4.2 and 2.11.4.3. The user must ensure that the requirements for each configuration stated above are met. If any questions or problems arise, the user is encouraged to contact the Kepco Applications Engineering group for technical assistance.

#### 2.12 REMOVING/REPLACING HSF POWER SUPPLIES



**Removal of an HSF power supply from a “live” system must be done only by authorized service personnel after HSF power switch is set to OFF. Dangerous voltages may be accessible through the open slot after a power supply is removed.**

Refer to PAR. 2.10 for instructions for removal and replacement of HSF power supplies.

#### 2.13 SHIPPING

The rack adapter may be shipped with power supplies installed *only* after each HSF power supply has been securely fastened to the rack adapter using six screws, four at the top and two at the bottom of the chassis (see NOTE to PAR. 2.9). Contact Kepco Applications Engineering if further assistance is required. Without power supplies the rack adapter weighs 16 lbs. (7.3Kg).



You must register your product to comply with the terms of the warranty. Either fill out the form below and mail or fax to Kepco, or for rapid on-line registration go to:

<http://www.kepcopower.com/warranty.htm>

**PRODUCT PURCHASED:**

Model Number) \_\_\_\_\_

Serial Number \_\_\_\_\_

**PURCHASE INFORMATION:**

Date Purchased: \_\_\_\_\_

Date Received: \_\_\_\_\_

**REQUEST ADDITIONAL INFORMATION**

Send complete Catalog

Have Sales Engineer Call

Contact via:  E-Mail  Telephone  Fax  S-mail

**REGISTER TO:**

Registered by: \_\_\_\_\_

Company Name: \_\_\_\_\_

Street: \_\_\_\_\_

City: \_\_\_\_\_

State: \_\_\_\_\_

Country: \_\_\_\_\_

Zip: \_\_\_\_\_

E-mail: \_\_\_\_\_

FAX: \_\_\_\_\_

Phone: \_\_\_\_\_

**WHAT INFLUENCED YOUR CHOICE OF THIS POWER SUPPLY?**

Previous Experience (which Kepco Models do you have?)  
\_\_\_\_\_  
\_\_\_\_\_

Magazines (which ones?) \_\_\_\_\_  
\_\_\_\_\_

Trade Shows (which ones?) \_\_\_\_\_

Directory? \_\_\_\_\_

Kepco Catalog or Brochure? \_\_\_\_\_

Sales Representative?

Web Site

Other (please explain): \_\_\_\_\_

What products would you like to see Kepco make?  
\_\_\_\_\_  
\_\_\_\_\_  
\_\_\_\_\_

CUT HERE

# Kepco 5 Year Warranty

This is to certify that we, KEPCO, INC., (hereinafter called "Company"), Flushing, NY 11352 USA, warrants for a period of FIVE YEARS, this instrument known as:

MODEL: \_\_\_\_\_

SERIAL NO. \_\_\_\_\_

The Company's products are warranted for a period of five years from date of delivery to be free from defects in materials and workmanship and to conform to the specifications furnished or approved by the Company. Liability under this warranty shall be limited to the repair or replacement of any defective product at Company's option.

If any defect within this warranty appears within the warranty period, the Purchaser shall promptly notify the Company in writing. No material will be accepted for repair or replacement without written authorization of the Company.

Upon such authorization, and in accordance with instructions of the Company, parts or materials for which replacement is requested shall be returned to the Company for examination, with shipping charges prepaid by the Purchaser. Final determination as to whether a product is actually defective rests with the Company.

This warranty does not extend to any product which has been subjected to misuse, neglect, accident, improper installation, or use in violation of instructions furnished by the Company. The warranty does not extend to, or apply to, any unit which has been repaired or altered outside of the Company's factory by persons not expressly approved by the Company.

THE WARRANTY HEREIN CONTAINED IS IN LIEU OF AND EXCLUDES ALL OTHER WARRANTIES, EXPRESS, IMPLIED OR STATUTORY, INCLUDING WITHOUT LIMITATION THE WARRANTY OF MERCHANTABILITY.

**THIS KEPCO PRODUCT IS WARRANTED FOR FIVE YEARS!**

KEPCO, INC. • 131-38 SANFORD AVENUE, FLUSHING, NY 11352 USA • Tel. 718-461-7000 • Fax. 718-767-1102  
E-mail: [hq@kepcopower.com](mailto:hq@kepcopower.com) • URL: <http://www.kepcopower.com>



FOLD HERE

Please  
place  
stamp  
here

KEPCO, INC.

131-38 SANFORD AVE.  
FLUSHING, NY 11352 USA

CUT HERE